



APPENDIX 9-2

ENERGY AND SUSTAINABILITY REPORT

Meath County Council - Viewing Purposes Only!

SITE C – STRATEGIC HOUSING DEVELOPMENT

ENERGY & SUSTAINABILITY REPORT

PROJECT NO: 21025

DATE: August 2022

Revision: 0

Parkbourne Consultancy Ltd,
Coliemoore House,
Coliemoore Road,
Dalkey,
Co Dublin.

Meath County Council - Viewing Purposes Only!

SITE C – STRATEGIC HOUSING DEVELOPMENTDOCUMENT RECORD

Revision No.	Description	Prepared By	Reviewed By	Date
Rev 0	Planning Issue	IMC	BMC	18.08.22

1.	EXECUTIVE SUMMARY	3
2.	INTRODUCTION.....	4
3.	PROJECT DESCRIPTION	4
4.	SUSTAINABILITY STATEMENT	5
5.	SUMMARY OF REQUIREMENTS	6
5.1	Nearly Zero Energy Buildings (NZEB)	6
5.2	Building Energy Rating (BER).....	7
5.3	Renewable Energy Ratio (RER)	7
5.4	Building Fabric	8
5.5	Building Envelope Air Permeability.....	9
5.6	Thermal Bridging	9
6.	SUSTAINABLE SERVICES.....	10
6.1	Air Source Heat Pumps	10
6.2	Domestic Hot Water Heat Pump for Apartments.....	11
6.3	Solar Photovoltaics	11
6.4	Indoor Air Quality	11
6.5	Thermal Comfort	12
6.5.1	Overheating Analysis	12
6.6	CO ₂ Levels	12
6.7	Nosie Levels	13
6.8	Water Conservation.....	13
6.9	Commissioning	13
6.10	Materials and Resources	13
6.11	Electric Vehicle Charging	14
6.12	Bicycle Facilities.....	14
6.13	Location and Transportation	14
7.	CONCLUSION	15

1. EXECUTIVE SUMMARY

Parkbourne Consulting Engineers were commissioned by Sky Castle Ltd. to provide an overview of how the project will integrate sustainability as a key strategy into the developments overall design. This report highlights the performance targets that are required by the Building Regulations Part L - Conservation of Fuel and Energy and what is required in order to achieve compliance. This development aims to achieve a BER rating of A2/A3 for all residential dwellings and a BER rating of A3 for the non-domestic buildings such as the Creche.

The report details the energy design approach that requires the design to initially focus on an energy demand reduction. The aim is to ensure the building has an energy efficient envelope which will reduce the demands for HVAC and renewable energy systems. This initial approach in reducing the energy demand significantly aids the project in obtaining the desired energy goals while reducing the running costs. Performance criteria relating to the developments building envelopes are set out within this document.

The energy systems design must also focus on specifying energy efficient equipment to ensure the day to day running of energy systems are optimised to further enhance energy savings and related energy costs. Specifications relating efficient heating, cooling, lighting and auxiliary equipment are also set out in this document.

This report confirms that if the energy and sustainability strategy is successfully implemented, the proposed Moygaddy Castle residential development will achieve all energy and sustainable targets.

2. INTRODUCTION

The intention of this report is to identify the energy efficiency measures associated with the design, construction, ongoing management and maintenance of the proposed Moygaddy Castle development located at Moygaddy, Co. Meath.

The proposed development will comply with Part L (2021) – Dwellings for the residential dwellings and Part L (2021) – Buildings Other Than Dwellings for the non-residential buildings. The residential areas of the development will target a A2/A3 BER rating while the non-residential areas will have a A3 BER rating target.

Extensive works have been carried out at the early stages to develop a sustainability strategy which can be carried through to completion. The onerous targets will contribute to the development's reduction in energy consumption, carbon emissions and the end users' operational costs.

3. PROJECT DESCRIPTION

Planning Permission is sought by Sky Castle Ltd. for the development of a site which extends to 19.52 hectares gross site area in the townland of Moygaddy, Maynooth Environs, Co. Meath. The net developable area equates to 7.89 hectares which equates to a residential density of 45.6 units per hectare.

The proposed development will consist of the following:

1. Construction of 360 no. residential units comprising:
 - i. 196 no houses (including 19 no. 2 beds, 156 no. 3 beds and 21 no. 4 beds).
 - ii. 102 no. duplexes (including 51 no. 1 beds and 51 no. 2 beds) set out in 6 no. blocks.
 - iii. 62 no. apartments (including 26 no. 1 beds and 36 no. 2 beds) set out in 2 no. blocks.
2. Provision of a public park and playground with associated 42 no. car parking spaces adjacent to Moygaddy Castle and pedestrian and cyclist links along the River Rye. The overall public open space (including the High Amenity Lands) equates to 7.98 hectares.
3. Provision of private open spaces in the form of balconies and terraces is provided to all individual apartments and duplexes to all elevations.
4. Development of a two-storey creche facility (514 sqm), outdoor play area and associated parking of 29 no. spaces.
5. Provision of a single storey Scout Den facility, including a hall, kitchen, meeting room and ancillary facilities (220sqm) and associated parking of 6 no. spaces.
6. Provision of 4 no. bridge structures comprising:
 - i. an integral single span bridge at Moyglare Hall over the River Rye Water to connect with existing road infrastructure in County Kildare and associated floodplain works and embankments.
 - ii. a new pedestrian and cyclist bridge at Kildare Bridge which will link the proposed site with the existing road network in County Kildare.
 - iii. a new pedestrian and cycle bridge across Moyglare Stream on the L6219 adjacent to the existing unnamed bridge.
 - iv. a new pedestrian and cycle bridge over the Moyglare Stream linking the proposed residential site with the proposed Childcare Facility, Scout Den and Moygaddy Castle Public Park.

7. Provision of 500m of distributor road comprising of 7.0m carriageway with turning lane where required, footpaths, cycle tracks and grass verges. All associated utilities and public lighting including storm water drainage with SuDS treatment and attenuation.
8. Proposed road improvement and realignment works including:
 - i. realignment of a section of the existing L6219 local road, which will entail the demolition of an existing section of the road which extends to circa 2,500 sqm.
 - ii. Provision of pedestrian and cycle improvement measures along the L6219 which abuts the boundary of Moygaddy House which is a Protected Structure (RPS ref 91558).
 - iii. Provision of pedestrian and cycle improvement measures along the R157 which abuts the Carton Demense Wall which is a Protected Structure (RPS Ref 91556).
9. Provision of 3 no. vehicular and pedestrian accesses from the L6219 local road and an additional vehicular and pedestrian access from the R157 to the Childcare and Scout Den facilities.
10. The proposed development will provide 283 no. of bicycle parking spaces, of which 200 no. are long term spaces in secure bicycle stores and 83 no. are short term visitor bicycle parking spaces. 12 no. bicycle spaces are provided for the creche and 12 no. bicycle spaces are provided for the Scout Den.
11. A total of 667 no. car parking spaces are provided on site located at surface level. The car parking provision includes 10 no. Electric Vehicle charging and Universally Accessible spaces allocated for the Apartment & Duplex units. All Houses will be constructed with provision for EV Charging.
12. Provision of site landscaping, public lighting, bin stores, 3 no. ESB unit substations, site services and all associated site development works.
13. A Natura Impact Statement (NIS) and Environmental Impact Assessment Report (EIAR) has been included with this application.

4. SUSTAINABILITY STATEMENT

The proposed Development is based on the requirements for Building Quality and Sustainable Design as set down in the Part L of the Irish Building Regulations along with best practice for environmental engineering in conjunction with the client's aspirations of achieving NZEB.

One of the major goals of the environmental sustainability strategy is to minimise energy demand and carbon emissions within the development. This will be achieved through a number of measures including the use of Heat Pumps, Mechanical Ventilation Heat Recovery (MVHR), Solar Photo-Voltaic systems and energy efficient lighting.

The following are a list of environmental strategies recommended for the development:

- Effective Shading
- Good solar access
- Building forms support daylight
- Adaptable and accessible service routes

5. SUMMARY OF REQUIREMENTS

The approach to sustainability for the residential development, in the first instance, is dictated by the Irish Building Regulations. The design will incorporate the principles of Near Zero Energy Buildings (NZEB) as defined under the Part L – Conservation of Fuel and Energy – Buildings other than Dwellings.

Building Regulations TGD Document Part L 2021 Conservation of Fuel and Energy - Dwellings

Part L of the Irish Building Regulations deals with fuel and energy and sets standards for the energy performance of non-domestic buildings.

A dwelling shall be designed and constructed so as to ensure that the energy performance of the dwelling is such as to limit the amount of energy required for the operation of the dwelling and the amount of carbon dioxide (CO₂) emissions associated with this energy use insofar as is reasonably practicable.

5.1 Nearly Zero Energy Buildings (NZEB)

“Nearly Zero Energy Buildings” is a building that has a very high energy performance, as determined in Annex I. The nearly zero or very low amount of energy required should be covered to a very significant extent by energy from renewable sources, including energy from renewable sources produced on-site or nearby.

For new buildings, the key issues to be addressed in order to ensure compliance are:

1. Providing that the energy performance of the building is such as to limit the calculated primary energy consumption and related carbon dioxide (CO₂) emissions to a Nearly Zero Energy Building level insofar as is reasonably practicable, when both energy consumption and carbon dioxide emission are calculated using Domestic Energy Assessment Procedure (DEAP);
2. Providing that, the nearly zero or very low amount of energy is covered to a very significant extent by energy from renewable sources including energy from renewable sources produced on-site or nearby;
3. Limiting the heat loss and, where appropriate, availing of the heat gains through the fabric of the building;
4. Providing and commissioning energy efficient space heating and water heating systems with efficient heat sources and effective controls
5. Providing to the building owner sufficient information about the building, the fixed building services, controls and their maintenance requirements so that the building can be operated in such a manner as to use no more fuel and energy than is reasonable.

5.2 Building Energy Rating (BER)

A Building Energy Rating (BER) certificate indicates the buildings energy performance on a grading scale on a scale of A1 to G with A1 being the most energy efficient.

A BER is calculated based on the amount of energy the home requires for;

- Building fabric
- Building orientation
- Thermal envelope
- Air permeability
- Space heating
- Domestic hot water heating
- Ventilation
- Lighting

The energy performance of the building is expressed as follows;

1. The primary energy use per unit floor area per year (kWh/m²/yr) represented on an A to G scale
2. The associated carbon dioxide (CO₂) emissions in kgCO₂/m²/yr.

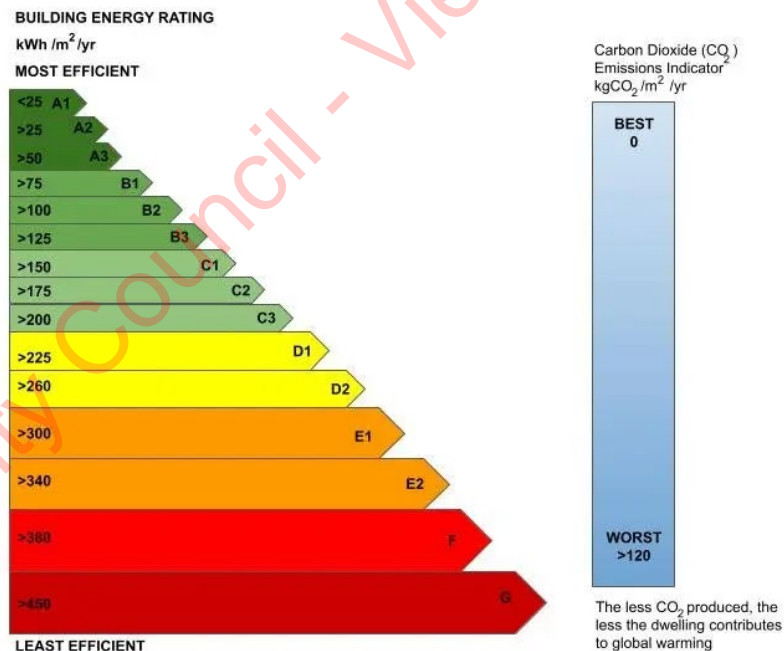

BER Chart

5.3 Renewable Energy Ratio (RER)

Renewable Energy Ratio is the ratio of the primary energy from renewable energy sources to total primary energy as defined and calculated in DEAP. Renewable energy technologies mean technology products or equipment that supply energy derived from renewable energy sources such as:

- Solar Thermal Systems
- Solar Photo-Voltaic Systems
- Wind Power
- Combined Heat & Power (CHP)
- Heat Pumps (Minimum COP of 2.5)
- Biomass Systems

Where the MPEPC of 0.3 and MPCPC of 0.35 are achieved, a minimum RER of 0.20 which represents 20% of the primary energy from renewable energy technologies is required.

5.4 Building Fabric

To limit the heat loss through the façade, careful consideration must be shown when designing the external façade. The specification of the insulation utilised, and the continuity of insulation are crucial. Insulation slows the rate at which heat is lost to the outdoors. Heat flows in three ways: by conduction, convection and radiation.

The target maximum average elemental U-Values for both residential and non-residential aspects of this development are detailed as follows:

FABRIC ELEMENTS	TARGETS (W/m ² K)
External wall	0.18
Ground floor	0.18 (0.15 if underfloor heating installed)
External doors, windows and rooflights	1.4
Pitched Roof	0.16
Flat Roof	0.18

Residential Building Envelope Thermal Performance Targets

FABRIC ELEMENTS	TARGETS (W/m ² K)
External wall	0.20
Ground floor	0.20 (0.15 if underfloor heating installed)
External doors, windows and rooflights	1.4
Pitched Roof	0.16
Flat Roof	0.20

Non-Residential Building Envelope Thermal Performance Targets

It is proposed that building fabric u-values equal or improved upon the minimum standards be applied. Such an approach allows for a further reduction in CO₂ emissions.

5.5 Building Envelope Air Permeability

In addition to fabric heat loss/gain, considerable care will be taken during the design and construction to limit the air permeability (Infiltration). High levels of infiltration can contribute to uncontrolled ventilation.

High levels of infiltration can contribute to uncontrolled ventilation. Infiltration is unlikely to provide adequate ventilation as required in the correct locations. It is important, as air permeability is reduced, that adequate purpose designed provided ventilation is provided.

Part L requires an air permeability level no greater than 5m³/m²/hr @ 50Pa for a new building which represents a reasonable upper limit of air tightness.

5.6 Thermal Bridging

To avoid excessive heat losses and local condensation problems, consideration will be given to ensure continuity of insulation and to limit local thermal bridging, e.g. around windows, doors and other wall openings, at junctions between elements and other locations.

Residential

The development dwellings will have target Y value of ≤ 0.08 W/m².K. in accordance with Part L (2021) – Dwellings requirements. The risks relating to mould growth/condensation risks will also be assessed, in accordance with Part L (2021) – Dwellings.

Non-residential

There are no Psi value targets required for non-domestic elements of the development. However, the risks to mould growth/condensation risks will still have to be assessed, in accordance with Part L (2021) – Buildings other than dwellings.

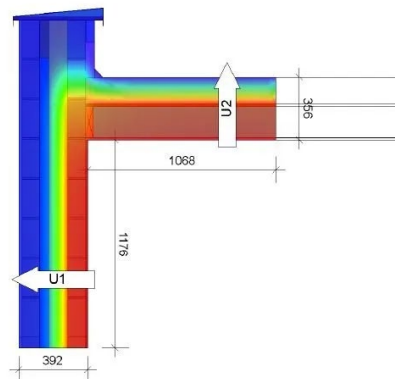

Thermal Bridge Assessment

6. SUSTAINABLE SERVICES

6.1 Air Source Heat Pumps

Air source heat pumps work by transferring heat from the outside air to the indoor space. The ASHP uses electricity to operate and are highly efficient. The ASHP external unit fan draws in air from the outside and transfers it to an evaporator which is located in the heat pump. A refrigerant circulates inside the heat pump, which changes the physical state and evaporates. This refrigerant steam is then compressed and the heat produced is transferred to the heating and hot water system.

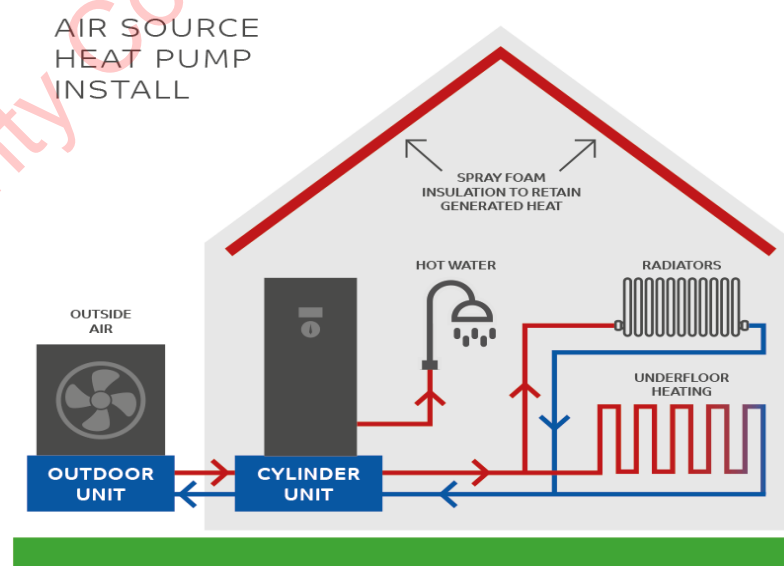

Air Source Heat Pump

6.2 Domestic Hot Water Heat Pump for Apartments

Similar to the air source heat pump, the domestic hot water heat pump extracts heat from the external air via insulated ductwork. They comprise of a stainless-steel inner vessel with a hot water heat pump mounted on top and produces hot water very efficiently. Depending on the apartments hot water demand the cylinder comes with options of 200L or 270L storage capacity.

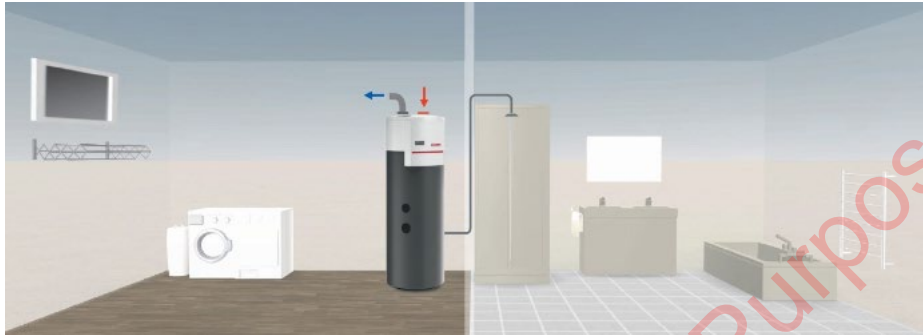

Domestic Hot Water Heat Pump for Apartments

6.3 Solar Photovoltaics

A photovoltaic (PV) panel, also known as a module, is a unit consisting of special cells that generate an electric current in sunlight that are linked together. When the sun shines over the cells, an electric field is created. The panels are located on the roof and are arranged in arrays. An inverter then converts the direct current (DC) into alternating current (AC). The produced electricity is then feed directly into the dwelling.

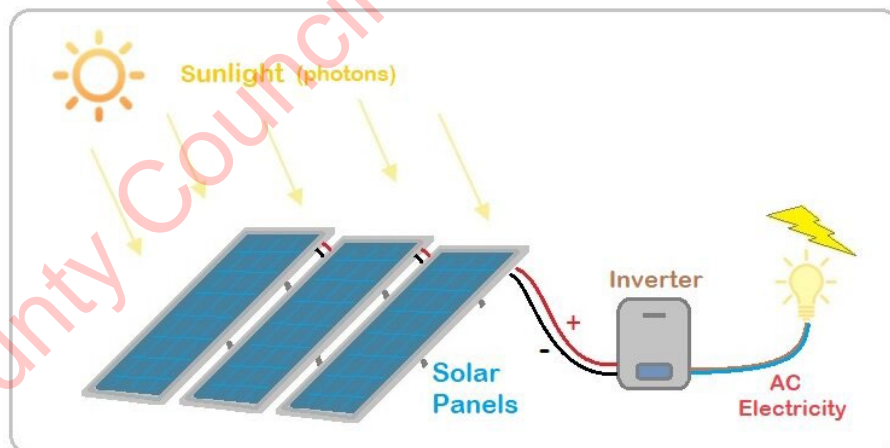

Solar PV

6.4 Indoor Air Quality

This is concerned with the health and comfort of all building occupants and is summarised as follows:

- Demand control ventilation (DCV) will be installed in all houses and duplexes to provide ventilation with low energy usage. The DCV system will extract stale/unwanted air from the wet rooms/kitchens controlled by presence and

humidity detectors and supply fresh air to all habitable rooms via humidity-controlled wall inlets;

- Mechanical Ventilation Heat Recovery Units (MVHR) will be installed in each apartment to provide ventilation with low energy usage. The MVHR reduces overall energy and ensures a continuous fresh air supply and controlled via presence and humidity detectors.

6.5 Thermal Comfort

Thermal comfort is reflected in the state of mind of the building occupants and is dependent the following:

- Air temperature
- Radiant temperature
- Air velocity
- Humidity
- Clothing levels
- Metabolism

The mechanical and electrical systems will be designed and operated to maximise control of these factors.

6.5.1 Overheating Analysis

Residential

The residential development will be evaluated and analysed with respect to overheating as detail in Part L (2021) – Dwellings and CIBSE TM59 Design Methodology for the assessment of Overheating Risk in Homes.

Non-Residential

The non-residential areas will be evaluated and analysed with respect to overheating as detail in Part L (2021) – Buildings other than Dwellings and CIBSE TM52 Limits of Thermal Comfort: Avoiding Overheating in European Buildings.

6.6 CO₂ Levels

For occupant comfort and efficiency, appropriate CO₂ levels need to be strictly controlled; by a combination of natural and mechanical ventilation. The ventilation system will be designed to maintain a maximum CO₂ concentration level of 600ppm.

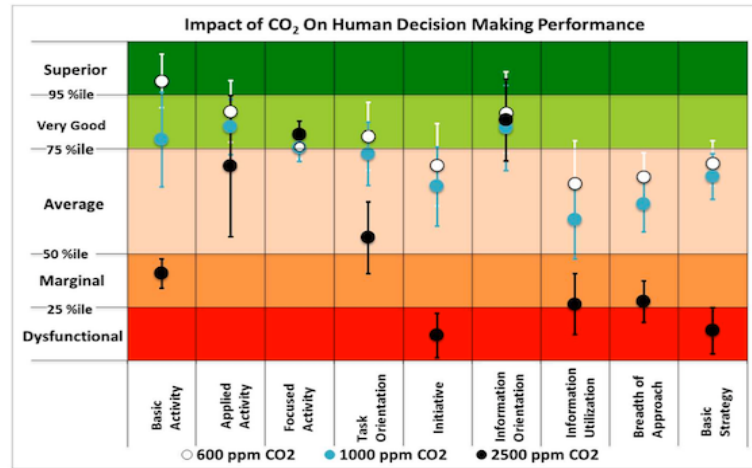

CO₂ Chart

6.7 Noise Levels

Low noise levels are important for good living conditions. Mechanical and electrical systems will be designed for lowest possible noise emission conducive with efficient operation.

Noise generated by the Mechanical & Electrical systems will be minimised by the use of acoustic panels where necessary.

6.8 Water Conservation

The following measures shall be implemented to assist with water conservation within the development:

- a. Low water use fittings and dual flush WCs

6.9 Commissioning

To ensure efficient operation of the development, all systems will be commissioned. Commissioning of a development's systems ensures that the sustainable energy-design can be fully realised, with fewer operational issues during the buildings lifetime. Buildings users productivity improves and operational costs decrease.

6.10 Materials and Resources

The development will be designed and operated with the aim of reduction in waste generation throughout the construction and operation. Where possible waste streams will be separated on site and recycled or re-used. Where possible local materials will be specified and in addition materials that contain recycled content will be considered as preferable.

6.11 Electric Vehicle Charging

Each house within the scheme will have an EV charging point located within the external ESB cabinet.

In addition, for the car parking allowance to the apartments and duplexes 10No. EV charging points will be installed.

Installation of cabling infrastructure will be allowed to all other car spaces for EV charging to allow for future installation.

6.12 Bicycle Facilities

Cycling offers a sustainable alternative to personal vehicles use, which reduces gas and particulate emissions, noise pollution and also congestion in busy urban areas. The proposed development will provide private bicycle spaces for tenants/occupants of the apartment in the scheme.

6.13 Location and Transportation

The proposed development will offer occupants travelling to and from the development alternative modes of transport other than the need to rely on a car. Developing in an area that has strong public transport nodes offers users the opportunity to travel to and from the site using alternative modes of transport such as bus stops, bicycle lanes and car sharing.

7. CONCLUSION

The intended Sustainability Strategy for the proposed Development shall be:

1. Compliance with the European Energy Performance of Buildings Directive through the application of NZEB for the Development
2. Air Source Heat Pump Technology
3. Application of the Development Energy Plan incorporating:
 - a. Effective Shading
 - b. Good solar access
 - c. Building forms support daylight
 - d. Adaptable and accessible service routes
4. Application of Renewable Technologies
5. Sustainable M&E Strategy comprising but not limited to:
 - a. Maintaining high qualities of Indoor Air Quality by efficient Mechanical means
 - b. Maintaining occupant thermal comfort
 - c. Limiting CO2 levels
 - d. Limiting noise levels
 - e. Water Conservation