



APPENDIX 9-2

ENERGY AND SUSTAINABILITY REPORT

Meath County Council - Viewing Purposes Only!

SITE A – STRATEGIC EMPLOYMENT ZONE

ENERGY & SUSTAINABILITY REPORT

PROJECT NO: 21025

DATE: August 2022

Revision: 0

Parkbourne Consultancy Ltd,
Coliemoore House,
Coliemoore Road,
Dalkey,
Co Dublin.

Meath County Council - Viewing Purposes Only!

1.	EXECUTIVE SUMMARY	3
2.	INTRODUCTION.....	4
3.	PROJECT DESCRIPTION	4
4.	SUSTAINABILITY STATEMENT	5
5.	SUMMARY OF REQUIREMENTS	5
5.1	Nearly Zero Energy Buildings (NZEB)	5
5.2	Building Energy Rating (BER).....	6
5.3	Renewable Energy Ratio (RER)	7
5.4	Building Fabric	7
5.5	Building Envelope Air Permeability.....	8
5.6	Thermal Bridging	8
6.	SUSTAINABLE SERVICES.....	9
6.1	Dedicated Energy Management System.....	9
6.2	Air Source Heat Pumps	10
6.2.1	Indoor Air Quality	10
6.3	Thermal Comfort	10
6.3.1	Overheating Analysis	10
6.3.2	CO ₂ Levels	11
6.3.3	Noise Levels	11
6.3.4	Water Conservation.....	11
6.4	Commissioning	11
6.5	Materials and Resources	12
6.6	Electric Vehicle Charging	12
6.7	Bicycle Facilities	12
6.8	Location and Transportation	12
7.	CONCLUSION	13

1. EXECUTIVE SUMMARY

Parkbourne Consulting Engineers were commissioned by Sky Castle Ltd. to provide an overview of how the project will integrate sustainability as a key strategy into the developments overall design. This report highlights the performance targets that are required by the Building Regulations Part L - Conservation of Fuel and Energy and what is required in order to achieve compliance. This development aims to achieve a BER rating of A3 for the Biotechnology and Medtech Office Campus Development.

The report details the energy design approach that requires the design to initially focus on an energy demand reduction. The aim is to ensure the building has an energy efficient envelope which will reduce the demands for HVAC and renewable energy systems. This initial approach in reducing the energy demand significantly aids the project in obtaining the desired energy goals while reducing the running costs. Performance criteria relating to the developments building envelopes are set out within this document.

The energy systems design must also focus on specifying energy efficient equipment to ensure the day to day running of energy systems are optimised to further enhance energy savings and related energy costs. Specifications relating efficient heating, cooling, lighting and auxiliary equipment are also set out in this document.

This report confirms that if the energy and sustainability strategy is successfully implemented, the proposed development will achieve all energy and sustainable targets.

2. INTRODUCTION

The intention of this report is to identify the energy efficiency measures associated with the design, construction, ongoing management and maintenance of the proposed Biotechnology and Medtech Office Campus development located on lands at Moygaddy, Co. Meath.

The Biotechnology and Medtech Office Campus will comply with Part L (2021) – Buildings Other Than Dwellings and will have target a A3 BER rating.

Extensive works have been carried out at the early stages to develop a sustainability strategy which can be carried through to completion. The onerous targets will contribute to the development's reduction in energy consumption, carbon emissions and the end users' operational costs.

3. PROJECT DESCRIPTION

The proposed development comprises 3 no. office blocks and all associated site development works (GFA: 20,633.26 sq.m) as follows:

- Block A: 5 storey office building providing offices, stair and lift cores and plant rooms (GFA: 10,260.42 sq.m)
- Block B: 3 storey office building providing offices, stair and lift cores and plant rooms (GFA: 5,186.54 sq.m)
- Block C: 3 storey office building providing offices, stair and lift cores and plant rooms (GFA: 5,186.30 sq.m)
- The development includes a surface car park which includes 323 no. car parking spaces and 320 no. bicycle car parking spaces (including 16 no. accessible car parking spaces and 12 no. EV charging infrastructure)
- Undertaking of road upgrade works including the provision of a signalised junction on the R157 Dunboyne Road and the construction of a section of the Maynooth Outer Orbital Route and provision of associated pedestrian and cycle infrastructure, as well as a realignment of a section of the R157. The works to the R157 adjoin the Carton Demense Wall which is a Protected Structure (RPS Ref 91556).
- Vehicular access to the site will be provided via the R157 Dunboyne Road and provision is made for a secondary vehicular access via the proposed section of the Maynooth Outer Orbital Route.
- Provision of water, foul and surface water drainage infrastructure including pumping station.
- Provision of a new pedestrian & cycle bridge structure at the River Rye Water adjacent to the existing Kildare Bridge.
- Provision of roof mounted solar PV panels on Office Blocks A, B & C.
- Provision of 3 no. ESB Kiosks.
- Provision of bin stores, bike stands, landscaping, boundary treatments and public lighting and all other site development works and services ancillary to the proposed development.

4. SUSTAINABILITY STATEMENT

The proposed Biotechnology and Medtech Office Campus is based on the requirements for Building Quality and Sustainable Design as set down in the Part L of the Irish Building Regulations along with best practice for environmental engineering in conjunction with the client's aspirations of achieving NZEB.

One of the major goals of the environmental sustainability strategy is to minimise energy demand and carbon emissions within the development. This will be achieved through a number of measures including the use of Heat Pump, Mechanical Ventilation Heat Recovery, Solar Photo-Voltaic systems and energy efficient lighting throughout.

The following are a list of environmental strategies recommended for the development:

- Effective Shading
- Good solar access
- Building forms support daylight
- Adaptable and accessible service routes

5. SUMMARY OF REQUIREMENTS

The approach to sustainability for the Biotechnology and Medtech Office Campus, in the first instance, is dictated by the Irish Building Regulations. The design will incorporate the principles of Near Zero Energy Buildings (NZEB) as defined under the Part L – Conservation of Fuel and Energy – Buildings other than Dwellings.

Building Regulations Part L (2021) for building other than dwellings

Part L of the Irish Building Regulations deals with fuel and energy and sets standards for the energy performance of non-domestic buildings.

A building shall be designed and constructed so as to ensure that the energy performance of the building is such as to limit the amount of energy required for the operation of the building and the amount of carbon dioxide (CO₂) emissions associated with this energy use insofar as is reasonably practicable.

5.1 Nearly Zero Energy Buildings (NZEB)

"Nearly Zero Energy Buildings" is a building that has a very high energy performance, as determined in Annex I. The nearly zero or very low amount of energy required should be covered to a very significant extent by energy from renewable sources, including energy from renewable sources produced on-site or nearby.

For new buildings, the key issues to be addressed in order to ensure compliance are:

- Providing that the energy performance of the building is such as to limit the calculated primary energy consumption and related Carbon Dioxide (CO₂) emissions

to a Nearly Zero Energy Building level insofar as is reasonably practicable, when both energy consumption and Carbon Dioxide emission are calculated using Non-domestic Energy Assessment Procedure (NEAP)

- Providing that, for buildings a very significant proportion of the energy consumption to meet the energy performance of the building is provided by renewable energy sources
- Limiting the heat loss and, where appropriate, availing of the heat gains through the fabric of the building
- Providing and commissioning energy efficient space heating and cooling systems, heating and cooling equipment, water heating systems, and ventilation systems, with effective controls
- Ensuring that the building appropriately designed to limit need for cooling and, where air conditioning or mechanical ventilation is installed, that installed systems are energy efficient, appropriately sized and adequately controlled
- Limiting the heat loss from pipes, ducts and vessels used for the transport or storage of heated water or air
- Limiting the heat gains by chilled water and refrigerant vessels, and by pipes and ducts that serve air conditioning systems
- Providing energy efficient artificial lighting systems and adequate control of these systems
- Providing to the building owner sufficient information about the building, the fixed building services, controls and their maintenance requirements so that the building can be operated in such a manner as to use no more fuel and energy than is reasonable.

5.2 Building Energy Rating (BER)

A Building Energy Rating (BER) certificated indicates the buildings energy performance on a grading scale on a scale of A1 to G with A1 being the most energy efficient.

A BER is calculated based on the amount of energy the home requires for;

- Building fabric
- Building orientation
- Thermal envelope
- Air permeability
- Space heating
- Domestic hot water heating
- Ventilation
- Lighting

The energy performance of the building is expressed as follows;

1. The primary energy use per unit floor area per year (kWh/m²/yr) represented on an A to G scale
2. The associated carbon dioxide (CO₂) emissions in kgCO₂/m²/yr.

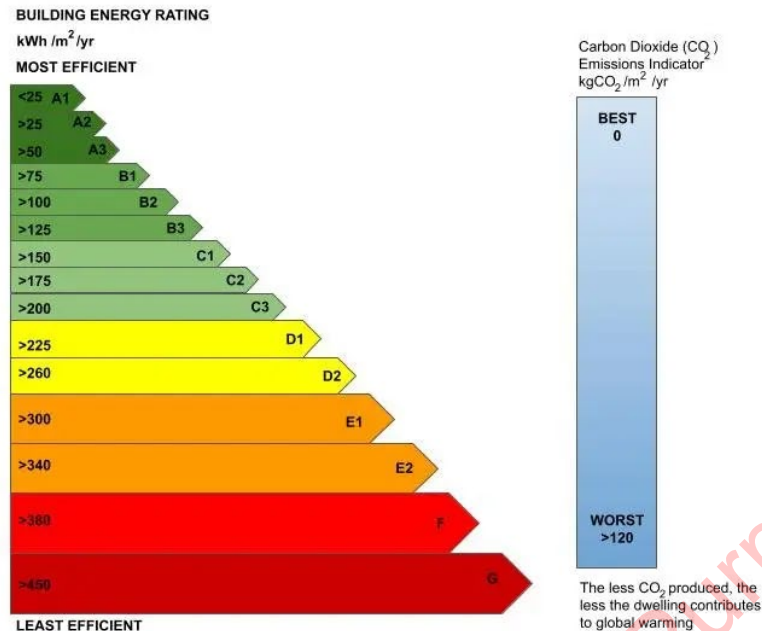

BER Chart

5.3 Renewable Energy Ratio (RER)

Renewable Energy Ratio is the ratio of the primary energy from renewable energy sources to total primary energy as defined and calculated in NEAP. Renewable energy technologies mean technology products or equipment that supply energy derived from renewable energy sources such as:

- Solar Thermal Systems
- Solar Photo-Voltaic Systems
- Wind Power
- Combined Heat & Power (CHP)
- Heat Pumps (Minimum COP of 2.5)
- Biomass Systems

5.4 Building Fabric

To limit the heat loss through the façade, careful consideration must be shown when designing the external façade. The specification of the insulation utilised, and the continuity of insulation are crucial. Insulation slows the rate at which heat is lost to the outdoors. Heat flows in three ways: by conduction, convection and radiation.

The target maximum average elemental U-Values for the buildings are detailed as follows:

FABRIC ELEMENTS	TARGETS (W/m ² K)
External wall	0.20
Ground floor	0.20 (0.15 if underfloor heating installed)
External doors, windows and rooflights	1.4
Pitched Roof	0.16
Flat Roof	0.20

Non-Residential Building Envelope Thermal Performance Targets

5.5 Building Envelope Air Permeability

In addition to fabric heat loss/gain, considerable care will be taken during the design and construction to limit the air permeability (infiltration). High levels of infiltration can contribute to uncontrolled ventilation.

High levels of infiltration can contribute to uncontrolled ventilation. Infiltration is unlikely to provide adequate ventilation as required in the correct locations. It is important, as air permeability is reduced, that adequate purpose designed provided ventilation is provided.

Part L requires an air permeability level no greater than 5m³/m²/hr @ 50Pa for a new building which represents a reasonable upper limit of air tightness.

5.6 Thermal Bridging

To avoid excessive heat losses and local condensation problems, consideration will be given to ensure continuity of insulation and to limit local thermal bridging, e.g. around windows, doors and other wall openings, at junctions between elements and other locations.

There are no Psi value targets required for non-domestic elements of the development. However, the risks to mould growth/condensation risks will still have to be assessed, in accordance with Part L (2021) – Buildings other than dwellings.

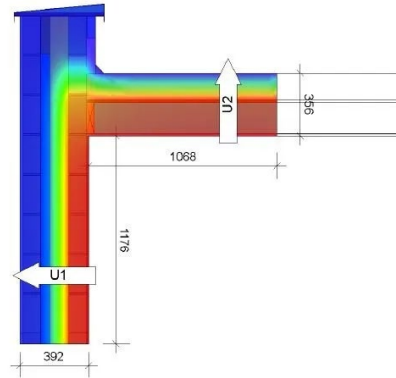

Thermal Bridge Assessment

6. SUSTAINABLE SERVICES

6.1 Dedicated Energy Management System

To ensure a sustainable approach across the development energy use across all development will be monitored with a dedicated energy management system. This system will enable maintenance to verify that performance standards are being achieved and to work towards continuous improvement in a systematic manner.

The energy management system will comprise a multi-point metering system and propriety energy management software that will monitor and target energy consumption across all systems, including non-energy systems such as general water services. The following systems and sub-systems will be monitored:

1. Thermal Systems
 - a. Low pressure hot water (LPHW) circuits for space heating
 - b. Low pressure hot water for domestic hot water generation
2. Electrical systems
 - a. Lighting circuits
 - b. Small power
 - c. Unregulated power supplies (plug loads)
 - d. HVAC systems
3. Water systems (plumbing)
 - a. Mains water
 - b. Cold water
 - c. Hot water use
 - d. Rain water harvesting

6.2 Air Source Heat Pumps

Air source heat pumps work by transferring heat from the outside air to the indoor space. The ASHP uses electricity to operate and are highly efficient. The ASHP external units fan draws in air from the outside and transfers it to an evaporator which is located in the heat pump. A refrigerant circulates inside the heat pump, which changes the physical state and evaporates. This refrigerant steam is then compressed and the heat produced is transferred to the heating and hot water system.

6.2.1 Indoor Air Quality

This is concerned with the health and comfort of all building occupants and is summarised as follows:

Air handling units (AHU) will be installed on all office blocks. This will circulate fresh air through ducts to each of the rooms in the buildings. In addition to managing the proper ventilation of the internal rooms with outside air the AHU will perform other functions:

- Filtration and control of the quality of the air that will reach the interior
- Control of the air temperature that regulates the air conditioning system in cold or hot so that the thermal sensation in the internal rooms is to the desired one
- Relative humidity monitoring for greater indoor comfort

6.3 Thermal Comfort

Thermal comfort is reflected in the state of mind of the building occupants and is dependent the following:

- Air temperature
- Radiant temperature
- Air velocity
- Humidity
- Clothing levels
- Metabolism

The mechanical and electrical systems will be designed and operated to maximise control of these factors.

6.3.1 Overheating Analysis

The non-residential areas will be evaluated and analysed with respect to overheating as detail in Part L (2021) – Buildings other than Dwellings and CIBSE TM52 Limits of Thermal Comfort: Avoiding Overheating in European Buildings.

6.3.2 CO₂ Levels

For occupant comfort and efficiency, appropriate CO₂ levels need to be strictly controlled; by a combination of natural and mechanical ventilation. The ventilation system will be designed to maintain a maximum CO₂ concentration level of 600ppm.

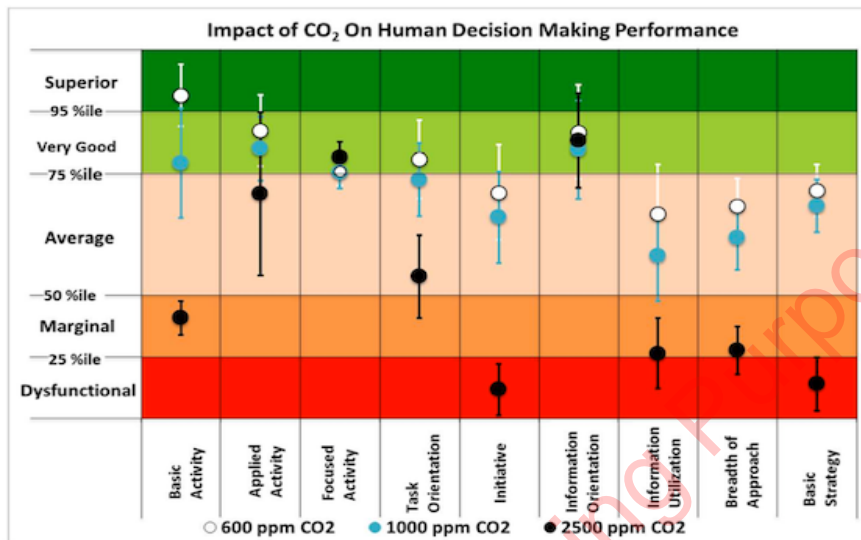

CO₂ Chart

6.3.3 Noise Levels

Low noise levels are important for good living conditions. Mechanical and electrical systems will be designed for lowest possible noise emission conducive with efficient operation.

Noise generated by equipment will be minimised by the use of acoustic panels where necessary strategically located throughout the building.

6.3.4 Water Conservation

The following measures shall be implemented to assist with water conservation within the development:

- a. Low water use fittings and dual flush WCs
- b. Water flow meters

6.4 Commissioning

To ensure efficient operation of the development, all systems will be commissioned. Commissioning of a development's systems ensures that the sustainable energy-design can be fully realised, with fewer operational issues during the buildings lifetime. Buildings users productivity improves and operational costs decrease.

6.5 Materials and Resources

The development will be designed and operated with the aim of reduction in waste generation throughout the construction and operation. Where possible waste streams will be separated on site and recycled or re-used. Where possible local materials will be specified and in addition materials that contain recycled content will be considered as preferable.

6.6 Electric Vehicle Charging

4No. EV chargers will be installed per office block.

Installation of cabling infrastructure will be allowed to all other car spaces for EV charging to allow for future installation.

6.7 Bicycle Facilities

Cycling offers a sustainable alternative to personal vehicles use, which reduces gas and particulate emissions, noise pollution and also congestion in busy urban areas. The proposed development will provide private bicycle spaces for occupants of the Biotechnology and Medtech Office Campus in the scheme.

6.8 Location and Transportation

The proposed development will offer occupants travelling to and from the development alternative modes of transport other than the need to rely on a car. Developing in an area that has strong public transport nodes offers users the opportunity to travel to and from the site using alternative modes of transport such as bus stops, bicycle lanes and car sharing.

7. CONCLUSION

The intended Sustainability Strategy for the proposed Development shall be:

1. Compliance with the European Energy Performance of Buildings Directive through the application of NZEB for the Development
2. Air Source Heat Pump Technology
3. Application of the Development Energy Plan incorporating:
 - a. Effective Shading
 - b. Good solar access
 - c. Building forms support daylight
 - d. Adaptable and accessible service routes
4. Application of Renewable Technologies
5. Sustainable M&E Strategy comprising but not limited to:
 - a. Energy Management and Monitoring System (CIBSE TM39)
 - b. Maintaining high qualities of Indoor Air Quality by efficient Mechanical means
 - c. Maintaining occupant thermal comfort
 - d. Limiting CO2 levels
 - e. Limiting noise levels
 - f. Water Conservation