

Interior – fourth floor

Room FO-1: Accessed from Rooms T-1 and FO-2. Stairwell accessing lower floors. Closed-string, U-plan staircase with timber treads and risers, with contrast strips to nosings and curved step to half-landing. Original balustrade up to half-landing comprised of oval-section timber handrail, with square-section cast-iron balusters alternated with cast-iron scrollwork panels at regular intervals, set to concrete steps. Modern plaster finish to walls. Single square-headed steel casement window to north wall at second floor landing. Carpet finish to landings.

Room FO-2: Accessed from Room FO-1. Open-plan space formed of concrete downstand bressummers bearing on diagonal concrete braces to walls, supported by square-section concrete columns at regular intervals. Modern plastered finish to ceiling. Cantled internal walls to east following plane of mansard roof, all finished in modern plaster. Evidence of buff brick substrate to south party wall. Multi-pane steel casement windows to east and west walls; plywood lining to reveals. Concrete finish to floor.



Plate 52: FO-1 – View to north-east; original balustrade



Plate 53: FO-1 – Curved timber step to half-landing



Plate 54: FO-1 – View to west from third floor landing



Plate 55: FO-2 – View to north

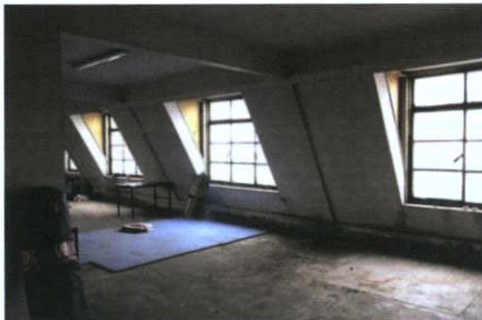

Plate 56: FO-2 – View to north-east



Plate 57: FO-2 – View to south-east



Plate 58: FO-2 – View to south

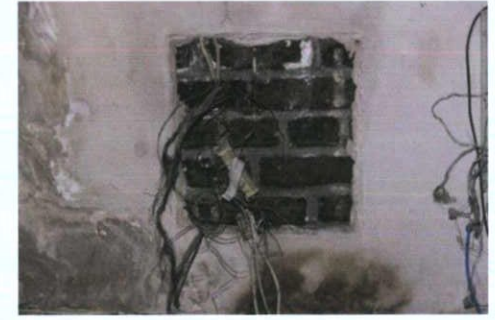

Plate 59: FO-2 – Brickwork to south party wall

EIAR Chapter 15 Cultural Heritage (Architectural)

Dublin Central Project – Site 2 & No.61 O'Connell Street Upper

Appendix 15.10 Building inventory, record and description for No.57 O'Connell Street Upper



57 O'Connell Street Upper, Dublin 1

Record of Protected Structures Reference:
6026, Commercial premises, Upper floor façade.

Other relevant Statutory Protections:
Within O'Connell Street ACA

NIAH Reference, rating:
50010541, Regional

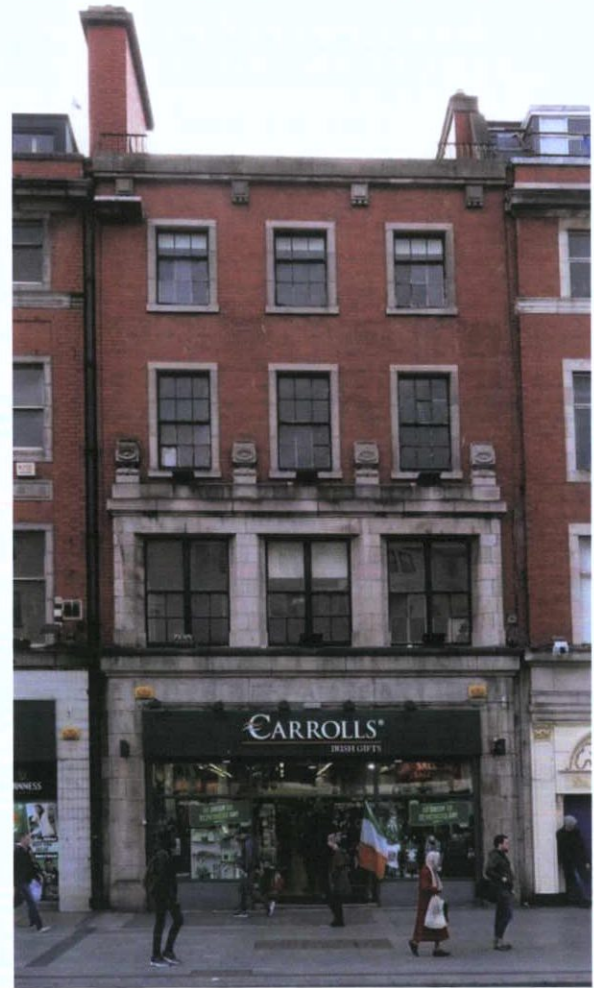

Proposed Building Site
Site 2ab

Planning history
Façade retained only; remainder of structure scheduled for demolition.

Outline building description
Four-storey, three-bay building faced with red brick laid in English garden wall bond on the upper floors. The shopfront is of granite ashlar bearing the incised name "A & R Thwaites & Co" on the fascia. The original fluted granite columns supporting the fascia are now missing.

At first-floor level there are three paired and mullioned windows, each sash having one-over-four configuration and the whole being framed in granite ashlar. On the upper floors the windows are framed with granite ashlar and there are three-over-six sashes on the top floor and six-over-six on the second floor. The parapet is of granite and has a wrought-iron railing. There are decorative elements of carved granite on the façade.

Occupancy
Occupied.

Plate 1: Front façade, 57 O'Connell Street Upper

DDC PLAN NO 5432/22
RECEIVED: 13/12/2022

BUILDING HISTORY

Number 57 O'Connell Street Upper was built as a private house in 1752. In 1813 the house was acquired by A & R Thwaites & Co., chemists and importers of mineral waters.¹ The firm had commenced its operations in Liffey Street in 1799 and had moved to Marlborough Street before acquiring the premises in what was then Sackville Street Upper to expand the business into larger premises.² The company claimed that the process for making the soda water had been invented by Augustine Thwaites junior in 1799; however, while the process itself was original, the company was not the first to manufacture soda water.

By 1893 the company had extended its buildings over the entire site at 57 Sackville Street Upper, as was shown on the Goad insurance map of that year.³ The four-storey building at the front was in use as offices, while to the rear was a two-storey building used for the manufacturing. At the Moore Lane frontage there were two-storey stores with a projecting wooden platform on the upper floor to facilitate a loading bay. The buildings in the centre and rear of the site were lit by roof lights along the ridge. The company had also expanded its operations into the rear of the adjoining building at 56 Sackville Street Upper, where they had a bottling and washing facility. Thwaites also had extensive stables at the rear of the Dorset Institution at 54 Sackville Street Upper.

The company was still in occupation in July 1922 when the premises were destroyed in the second battle of O'Connell Street.⁴ A replacement building was erected on the site from 1924 and was completed in 1926.⁵ The Goad insurance plan that was published in that year suggests that most of the buildings on the rear site survived the destruction, with only the front building and a small area behind it being rebuilt.⁶ The insurance plan shows that the new building had a concrete roof and the rooms at the front and those at the rear were separated by a stone staircase and a light well roofed with glazing, while between the stairs and the light well was a corridor. The plan also shows that the basement area to the front of the building, which had been present in 1893, had now been covered over and lit by pavement lens lighting. A contemporary photograph of the front of the building shows that the original shopfront was supported on two granite Doric columns, now missing.

In the mid-1920s a new company, Mineral Water Distributors Ltd, was established and Thwaites became part of that firm, along with Cantrell & Cochrane.⁷ Thwaites was in occupation of number 57 O'Connell Street Upper until about 1940 and from the mid-1930s the building was also occupied by a wine and spirit merchant, with offices above.⁸ Number 57 was subsequently occupied by a variety of retail outlets and offices and since the 1990s the ground-floor shop unit has been occupied by Carroll's.⁹



Figure 1: Elevation of 57 Sackville Street Upper from Shaw's Directory of 1850



Figure 2: Façade of A & R Thwaites, c1890 (Irish Architectural Archive)



Figure 3: Façade following reconstruction, 1926

¹ Wilson's *Dublin Directory*, 1812 and 1814; Registry of Deeds book 647, page 293, number 445475.

² Spencer Blackett, 1888, *The Industries of Dublin*, London, p. 47.

³ Goad, Charles, *Insurance Plan of the City of Dublin*, 1893, sheet 4.

⁴ *Irish Independent*, 6th July 1922.

⁵ Dictionary of Irish Architects, www.dia.ie.

⁶ Goad, Charles, *Insurance Plan of the City of Dublin*, 1926, sheet 4.

⁷ *Irish Times*, 27th November 1928.

⁸ *Thom's Directory*, 1921 to 1940.

⁹ *Thom's Directory*, 1940 to 2012.

FLOOR PLANS

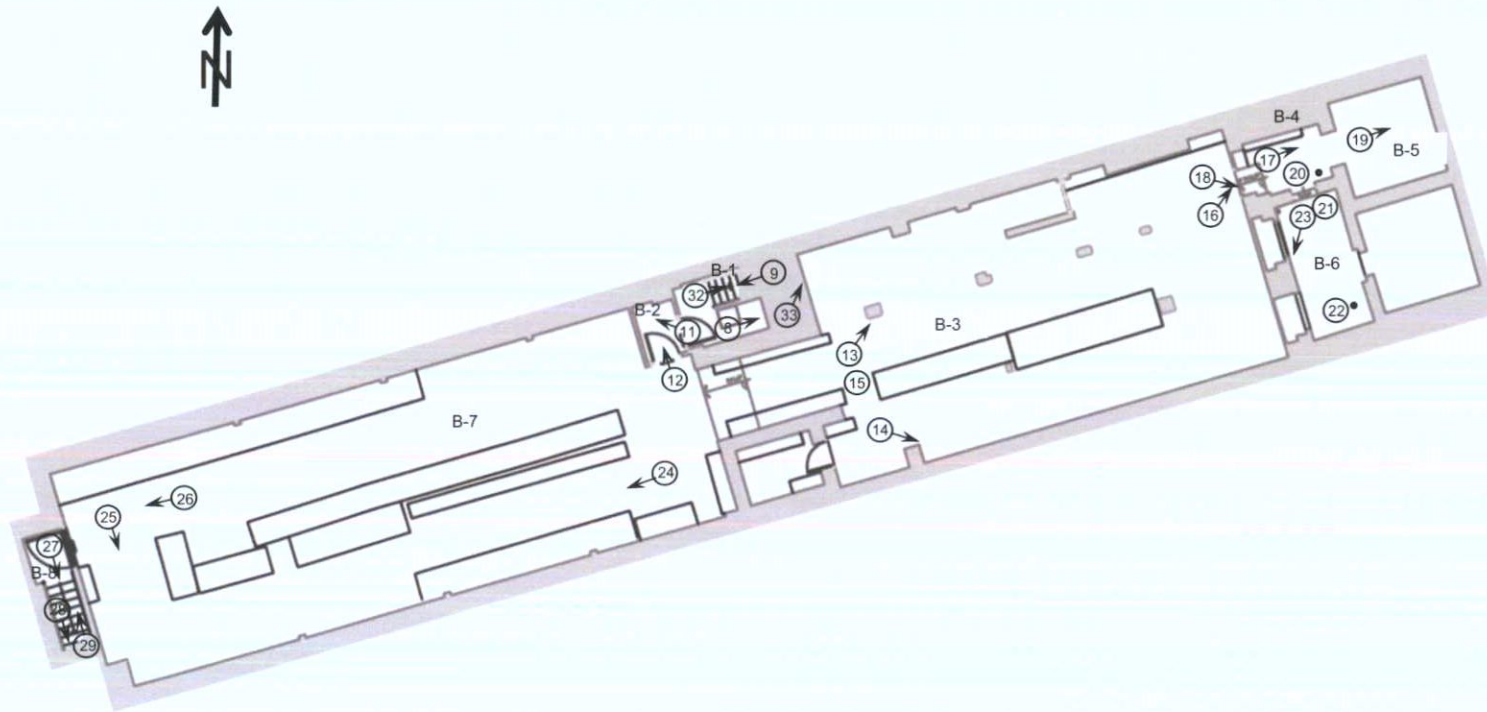

Figure 4: Plan at basement level

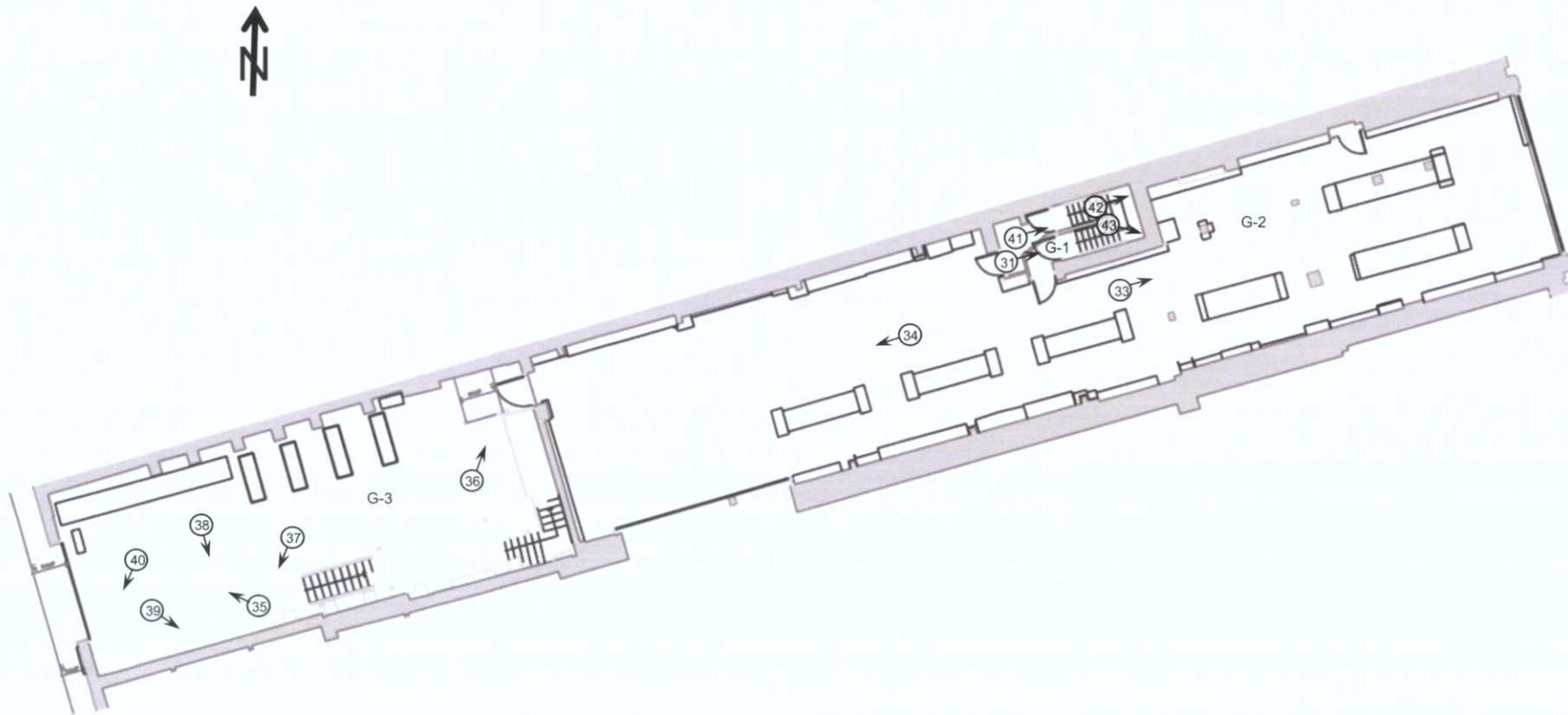

Figure 5: Plan at ground floor level

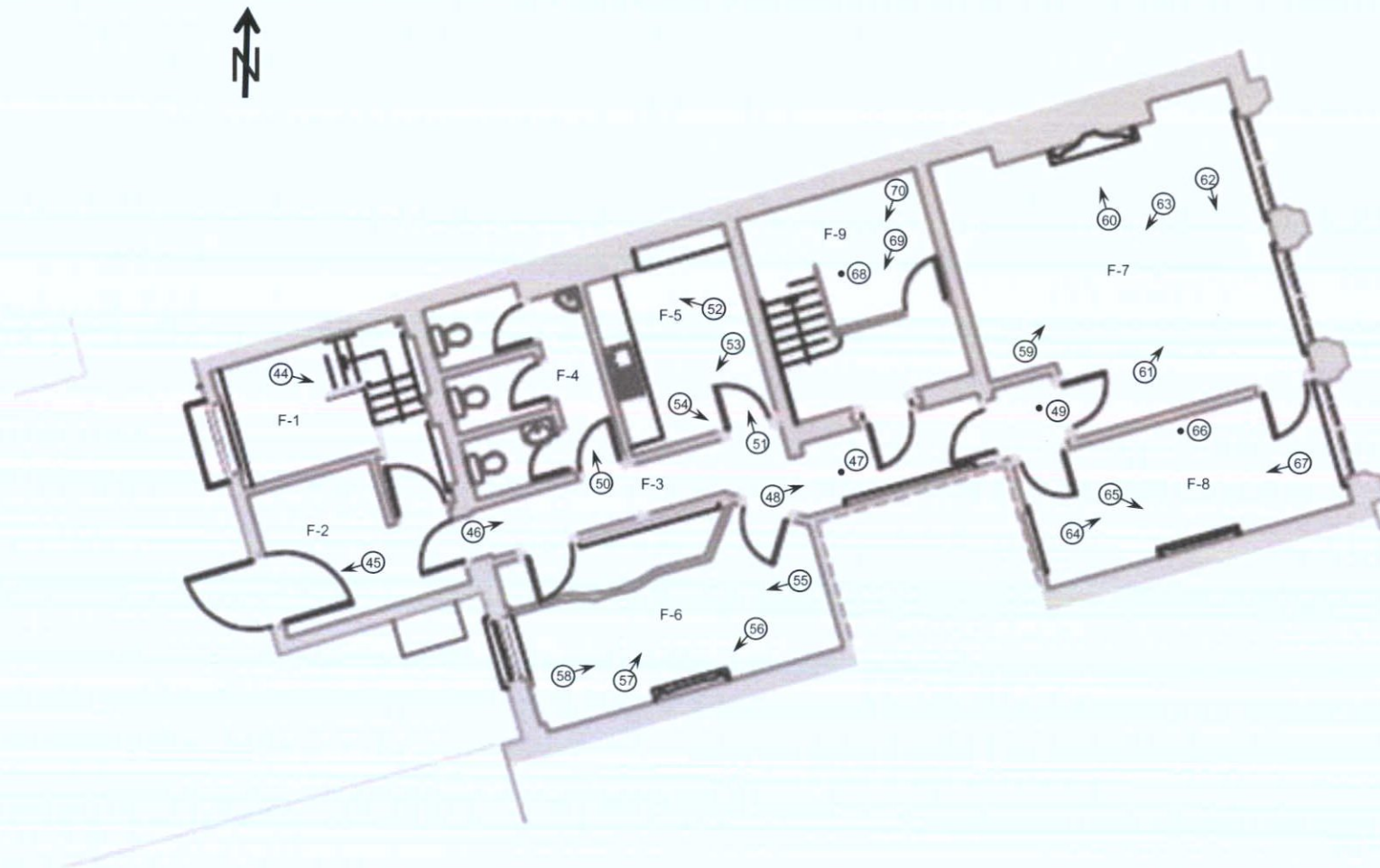

Figure 6: Plan at first floor level

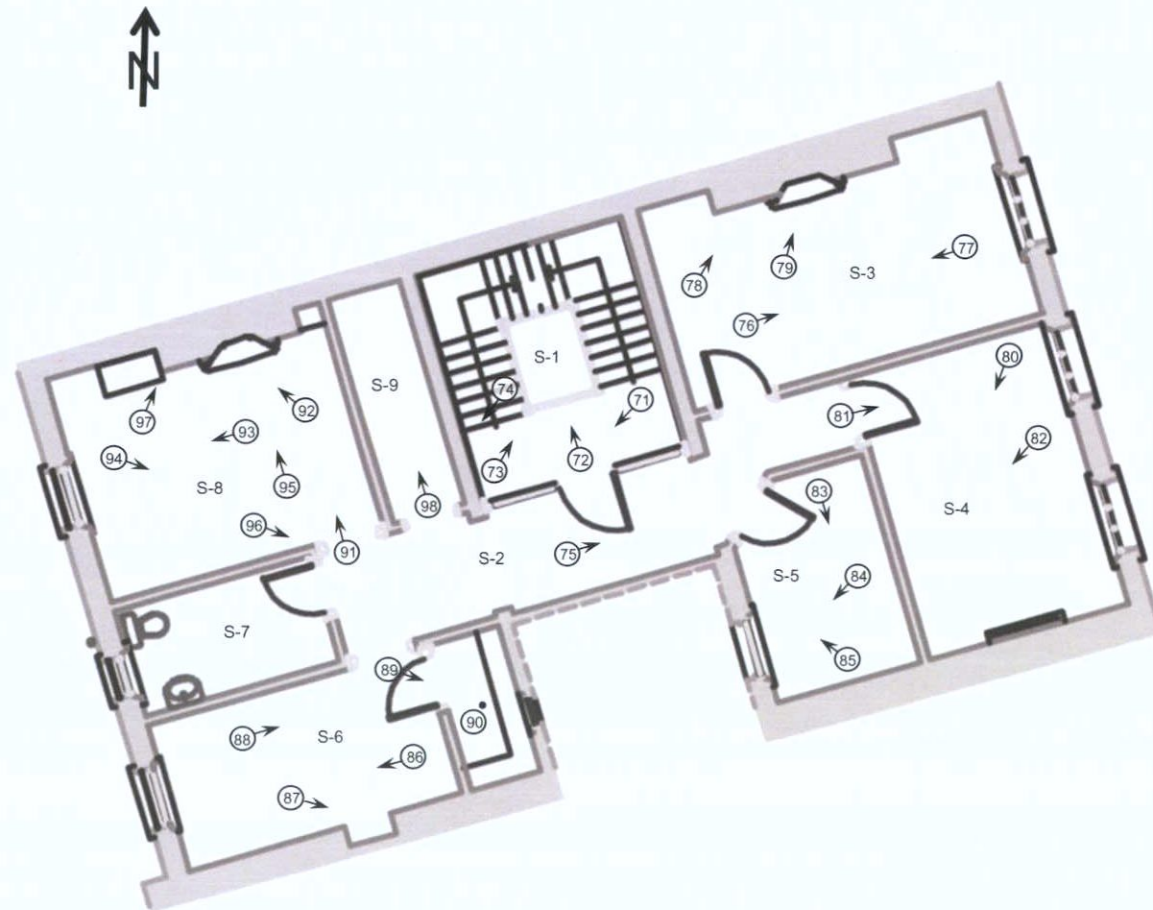

Figure 7: Plan at second floor level



Figure 8: Plan at third floor level

BUILDING SURVEY

Exterior

Three-bay, four-storey-over-basement attached building. Flat roof, having double-pitched rooflight to centre plan and open lightwell to south. Buff brick chimneystack to north-west; red brick chimneystack to north-east; rendered chimneystacks to south being paired with and located over chimneystacks to Number 58. Carved granite parapet with wrought-iron railing and projecting blocking course supporting on stylised carved granite brackets with gigantic order guttae. Front (east) façade comprised of red brick laid in English garden wall bond, over projecting granite ashlar, tripartite breakfront, having cornice and blocking course of carved granite ashlar surmounted by stylised granite medallions. Three, paired mullioned windows with one-over-four timber sash windows. Six-over-six timber sash windows to second floor and three-over-six timber sash windows to third floor, all having granite ashlar surrounds and sills. Granite ashlar shop front with solitary plinths flanking either side of modern shopfront infill; incised lettering to fascia reading, "A & R THWAITES & CO."

Rear (west) elevation comprised of buff brick laid in English garden wall bond. Wrought-iron railings to granite copings. One-over-one timber sash windows with external cast-iron security grilles and granite sills; granite lintels. Mix of cast-iron and cast-aluminium rainwater goods.

Extensions with flat roofs to west. Double-height extension to rear fronting onto Moore Lane, constructed of buff brick laid in English garden wall bond with roughly coursed Calp limestone at low level large vehicular opening enclosed with steel roller shutter with steel upstand over. Buff brick and concrete blockwork to reveals; evidence of former window opening to south; granite sill retained.

The rear elevation onto Moore Lane is marked by a vehicular entrance closed by a steel roller shutter, above which is an area of steel sheeting. On either side of the entrance the walling is of brick and Calp limestone augmented by areas of mass concrete and concrete blockwork. The edge of one of the bricks on the southern side of the entrance is broken and this may mark the impact of a bullet during the 1916 Rising.



Plate 2: Third floor sash window

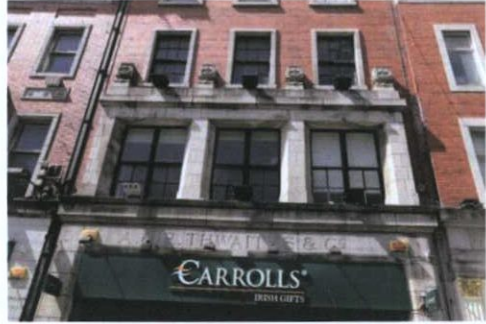

Plate 3: Detail to first floor



Plate 4: Limestone bracket



Plate 5: Commercial shop front



Plate 6: Rear (west) elevation



Plate 7: View to extensions from south



Plate 8: Rear elevation of extension onto Moore Lane

DDC PLAN NO 5432V22
2022

Interior – basement

Room B-1: Accessed from Rooms G-1 and B-2. Stairwell accessing ground and first floors. Closed-string, dog-leg staircase, with squared steel treads and risers. Flat steel handrail affixed to north wall. Plasterboard finish to ceiling and to soffit of rising staircase. Plasterboard finish to west wall; brickwork laid in English garden wall bond to north and south, painted to north, with modern plaster to east wall and to inner partition wall. Rectangular-section skirting boards / stringers. Flush timber doors with flat timber architraves. Concrete finish to floors.

Room B-2: Accessed from Rooms B-1 and B-3. Cementitious plaster to ceiling. Cement board finish to walls; substrate of concrete blockwork noted to north wall. Flush timber doors with flat timber architraves. Concrete finish to floor.

Room B-3: Accessed from Rooms B-2, B-4 and B-7. Open-plan space formed of square-section concrete columns at regular intervals supporting downstand concrete bressummers. Cement board finish to recessed ceiling. Modern plaster and limewash finishes to walls. Concrete floor finish; floor and ceiling ramp downward to west at centre plan. Modern shelving and commercial storage fittings throughout.

Room B-4: Accessed from Rooms B-3, B-5 and B-6. Cementitious plaster to ceiling and to walls. Low-level opening to east wall providing access into 18th century cellar in Room B-5 indicates red brick construction. Carved door frame to south providing access into Room B-6. Timber beaded doors to built-in service press to north. Concrete finish to floor. Surface-mounted services. Water tank storage.



Plate 9: B-1 – View to west to basement level

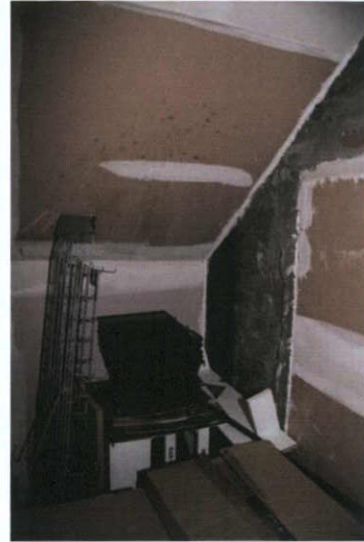

Plate 10: B-1 – View to east at basement level



Plate 11: B-2 – View to west

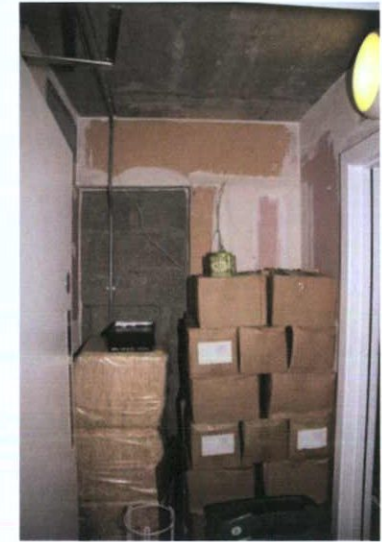

Plate 12: B-2 – View to north



Plate 13: B-3 – View to north-east



Plate 14: B-3 – View to south-east



Plate 15: B-3 – View to south



Plate 16: B-4 – View to north-east

Interior – basement

Room B-5: Accessed from Room B-4. Barrel-vaulted 18th century cellar, with ceiling continuous to walls. Red brick ceiling and walls to north, south and west; Calp limestone wall to east. Earthen floor. Surface-mounted services.

Room B-6: Accessed from Room B-4. Ceiling supported by cross braces of steel supported on matching frame and brackets to perimeter, with plywood covering over. Walls finished in cementitious plaster. Non-accessible opening in east wall. Concrete floor finish. Surface-mounted services.

Room B-7: Accessed from Rooms B-2, B-3, and B-8. Open-plan space. Cast concrete finish to ceiling. Concrete blockwork to walls. Evidence of red brick, buff brick and Calp limestone wall substrate to north wall. Steel door to rear accessing Room B-8. Concrete floor finish. Modern shelving and commercial storage fittings throughout.



Plate 17: B-4 – View to east

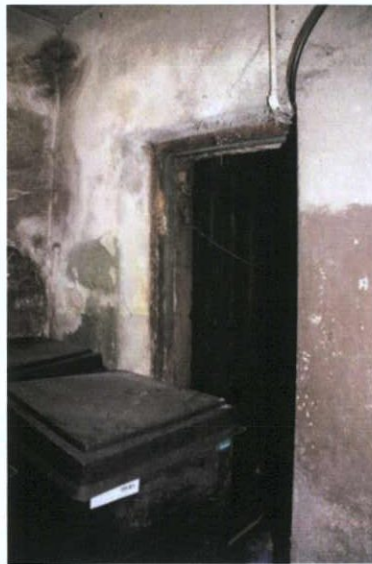

Plate 18: B-4 – View to south-east – access to B-6



Plate 19: B-5 – View to east – 18th-century vault



Plate 20: B-5 – Downstand of front elevation



Plate 21: B-6 – View to south



Plate 22: B-6 – Steel supports to ceiling



Plate 23: B-6 – View to south-west



Plate 24: B-7 – View to west

Interior – basement

Room B-8: Accessed from Rooms B-7 and G-3. Stairwell accessing ground floor to extension. Straight flight of closed-string stairs, with squared concrete treads and risers. Exposed ceiling joists over. Cementitious plaster to east, north and west walls; east wall stepping in at mid-height. Red brick construction to south wall, with matching, projecting pier and evidence of previous construction, now disassembled. Steel door with matching architrave. Concrete finish to floors.



Plate 25: B-7 – View to south



Plate 26: B-7 – View to west; entrance to Room B-8



Plate 27: B-8 – View to south



Plate 28: B-8 – View to south towards party wall



Plate 29: B-8 – View to north from upper landing

Interior – ground floor

Room G-1: Accessed from Rooms B-1 and G-2. Stairwell accessing basement and first floors. Closed-string, dog-leg staircase, with squared steel treads and risers. Flat steel handrail affixed to south wall. Plasterboard finish to ceiling and to soffit of rising staircase. Painted brickwork to south and east walls; former window opens at basement and ground floor levels to east and south walls, now blocked up, retaining painted masonry sills. Plasterboard finish to inner partition wall. Rectangular-section skirting boards / stringers. Flush timber doors with flat timber architraves. Concrete finish to floors.

Room G-2: Accessed from Rooms G-1, G-3 and external entrance from O'Connell Street Upper. Open-plan space formed of squared columns supporting ceiling at regular intervals; suspended ceiling finished with ceiling tiles. Plasterboard finishes to walls, with some commercial timber fit-out linings. Flush timber doors and flat timber architraves. Ceramic tile finish to floor.

Room G-3: Accessed from Room G-2 and from Number 58 O'Connell Street Upper. Former rear industrial site / rear garden, now internalised. Ceiling formed of I-beams on north-south axis, affixed to flanking walls with steel brackets, with recessed infill of corrugated sheeting above, exposed to below. Walls to north and south comprised of painted red and buff brick, and rubble Calp limestone, finished in areas with limewash and cementitious render. Projecting, engaged piers to north wall comprised of concrete blockwork. Squared granite corbel brackets projecting from north and south walls at regular intervals. Cementitious plaster to east wall. Large vehicular opening to west wall, enclosed with steel roller shutter. Opening in party wall to south-west corner, formed with concrete lintel, accessing Number 58 O'Connell Street Upper. Tarmacadam finish to floor, with undulations in floor level. Steel staircase to south leading to first floor mezzanine. Surface-mounted services.



Plate 30: G-1 - View down stairway



Plate 31: G-1 - Blocked window at side of stairway

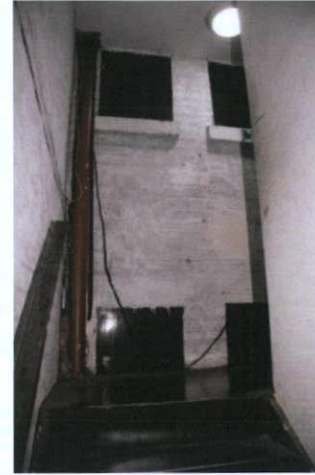

Plate 32: G-1 - Blocked windows to east of stairway



Plate 33: G-2: View east in ground-floor shop



Plate 34: G-2 - View west in ground-floor shop

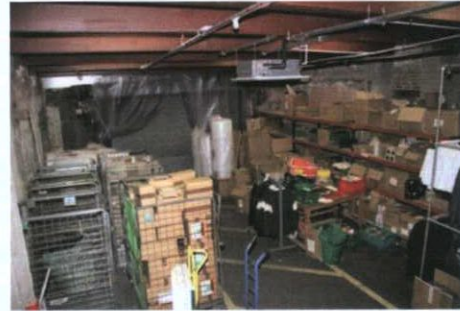

Plate 35: G-3 - View west toward rear entrance

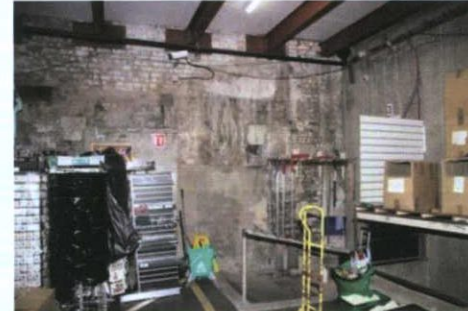

Plate 36: G-3 - View north



Plate 37: G-3 – View south



Plate 38: G-3 - View south



Plate 39: G-3: Granite corbel in southern wall



Plate 40: G-3 – Entry to rear of 44 O'Connell Street Upper

DDC PLAN NO 54/32/22
12/2022

Interior – first floor

Room F-1: Accessed from Rooms G-1 and F-2. Stairwell accessing ground and upper floors. Closed-string, dog-leg staircase, with squared steel treads and risers. Flat steel handrail. Plasterboard finish to soffit of rising staircase; suspended ceiling finished with ceiling tile to top of stairwell. Painted brickwork to all outer walls; former window opens at ground and first floor levels to east wall, now blocked up, retaining painted masonry sills; high-level window to west wall acting as steel AOV. Plasterboard finish to inner partition wall. Rectangular-section skirting boards / stringers. Flush timber doors with flat timber architraves. Surface-mounted services.

Room F-2: Accessed from Room F-1. Suspended ceiling finished with ceiling tiles. Modern plaster to walls. Square-headed door opening to west elevation accessing flat roof. Vinyl finish to floor.

Room F-3: Accessed from Rooms F-2, F-4, F-5, F-6, F-7, F-8 and F-9. Central corridor on east-west axis, located within original rear, south-west room. Lath-and-plaster ceiling, with original moulded coving noted to north, west and east walls; additional original moulding to square-plan vestibule to corridor formed between Rooms F-7 and F-8 to east. Non-original timber stud partition, finished in plasterboard, to south forming Room F-6; similar finish to downstand nib of new partition to east forming partition between Rooms F-4 and F-5. Flush timber doors and flat timber architraves. Blocked-up window opening to south wall, formerly overlooking internal lightwell. Original timber skirting boards with ovolo profile to north, west and east walls. Vinyl finish to floor.



Plate 41: F-1 – View to east



Plate 42: F-1 – Former window openings



Plate 43: F-1 – View to east; blocked-up window openings



Plate 44: F-1 – Window at high level to east



Plate 45: F-2 – View to west



Plate 46: F-3 – View to east



Plate 47: F-3 – Coving over central corridor



Plate 48: F-3 – View to west

Interior – first floor

Room F-4: Accessed from Room F-3. WC located within original rear, north-west room. Lath-and-plaster ceiling, with original moulded coving noted to north wall only. Non-original timber stud partition, finished in plasterboard, to east forming Room F-5; additional timber stud partition to west forming toilet cubicles. Modern plaster finish to north, west and south walls; original chimney breast projecting from north wall and subsumed by toilet cubicle partition. Ceramic tile to walls at lower level. Flush timber doors and flat timber architraves. Ceramic tile finish to floor. Sanitaryware throughout.

Room F-5: Accessed from Room F-3. Kitchenette located within original rear, north-west room. Portion of projecting original chimney breast legible to north wall; intersected by modern partition. Lath-and-plaster ceiling, with original moulded coving noted to north and east walls only. Non-original timber stud partition, finished in plasterboard, to west forming Room F-4. Modern plaster finish to north, east and south walls. Flush timber door and original carved timber architraves on plinth blocks. Original timber skirting with ovolo profile to south, north and east walls. Ceramic tile finish to floor. Kitchenette facilities to west.

Room F-6: Accessed from Room F-3. Staff room located within original rear, south-west room. Lath-and-plaster ceiling, with original moulded coving noted to west, south and north walls and to canted entrance to north-east. Non-original timber stud partition, finished in plasterboard, to north forming small closet accessed from Room F-3. Modern plaster finish to north, west and south walls. Flush chimney breast to south wall, with original timber chimney piece comprised of integrated overmantel with carved timber pilasters flanking segmental-headed mirror and supporting timber cornice, over mantel supported on corbel brackets, with ceramic tile to fire surrounds; steel plate blocked up fireplace. Flush timber doors and flat timber architraves. Skirting boards with ovolo profile to north, west and south walls. Picture rail to north, south and west walls. One-over-one timber sash window to west wall having carved timber architrave and nosed internal timber sill; window intersected by non-original partition. Vinyl finish to floor.

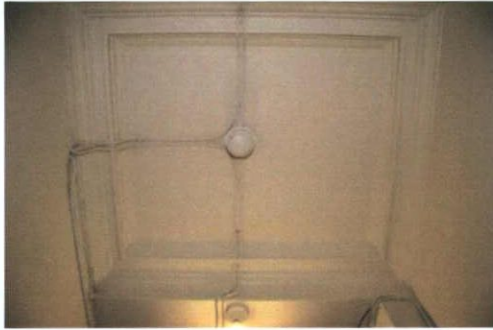

Plate 49: F-3 – Detail to coving to eastern end of corridor



Plate 50: F-4 – View to north



Plate 51: F-5 – View to north

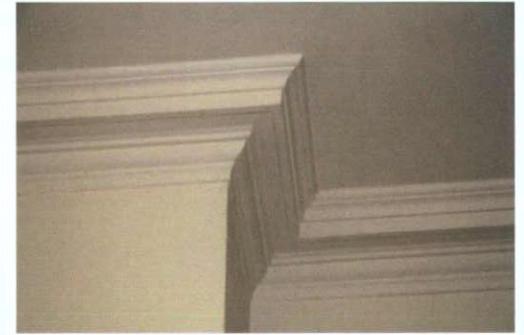

Plate 52: F-5 – Detail to coving



Plate 53: F-5 – View to south-west



Plate 54: F-5 – View to south-east



Plate 55: F-6 – View to west

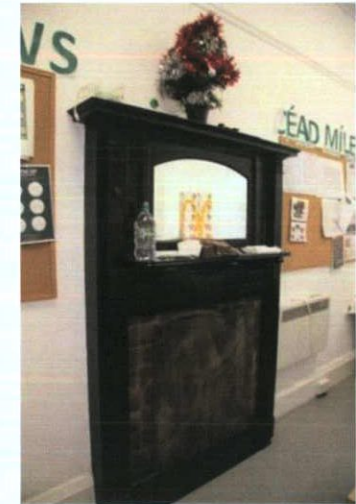

Plate 56: F-6 – View to south-west

Interior – first floor

Room F-7: Accessed from Rooms F-3 and F-8. Lath-and-plaster ceiling, with original moulded coving. Plaster finish to walls, some with lining paper over. Projecting chimney breast to north wall, original timber chimney piece comprised of integrated overmantel with carved engaged columns with fluted capitals flanking square-headed mirror and supporting timber cornice, over nosed mantel, with ceramic tile to fire surrounds. Original timber panelled door and flush timber door set to carved timber architraves on plinth blocks. Skirting boards with ovolo profile. Picture rail to perimeter walls. Paired mullioned windows with one-over-four timber sashes having carved timber architraves and nosed internal timber sills. Linoleum finish to floor.

Room F-8: Accessed from Rooms F-3 and F-7. Lath-and-plaster ceiling, with original moulded coving. Plaster finish to walls, some with lining paper over. Flush chimney breast to south wall, original timber chimney piece comprised of integrated overmantel with carved engaged columns with fluted capitals flanking square-headed mirror and supporting timber cornice, over nosed mantle, with ceramic tile to fire surrounds. Original timber panelled door and flush timber door set to carved timber architraves on plinth blocks. Skirting boards with ovolo profile. Picture rail to perimeter walls. Paired mullioned window with one-over-four timber sashes having carved timber architrave and nosed internal timber sill. Blind window to west elevation, having carved timber architrave and nosed internal timber sill, formerly overlooking internal lightwell. Linoleum finish to floor.



Plate 57: F-6 – View to north-east



Plate 58: F-6 – View to east



Plate 59: F-7 – View to north



Plate 60: F-7 – Detail to chimney piece



Plate 61: F-7 – View to east



Plate 62: F-7 – View to south



Plate 63: F-7 – View to south-west



Plate 64: F-8 – View to east

Interior – first floor

Room F-9: Accessed from Rooms F-3 and S-1. Stairwell accessing upper floors. Closed-string, open-well staircase with quarter landings; nosed timber treads and timber risers with rubber contrast strips; balustrade formed of carved, ramped timber handrail, set to square-section newel posts at landings with pyramidal cappings, with heavily turned balusters set to stringer with ovolo profile to arrises; drop finials. Lath-and-plaster finish to ceiling and to soffit of rising staircase. Plaster finish to walls. Original timber panelled doors set to carved timber architraves on plinth blocks. Original skirting boards with ovolo profile. Carpet finish to landings.



Plate 65: F-8 – Chimney piece to south wall



Plate 66: F-8 – View of ceiling

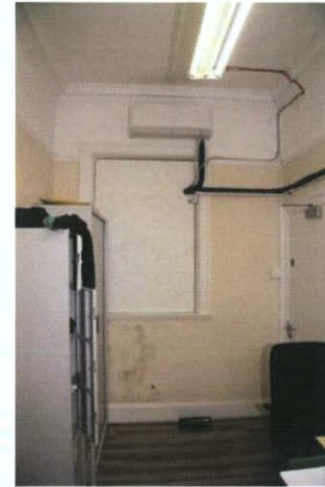

Plate 67: F-8 – View to west; blind window formerly overlooking lightwell

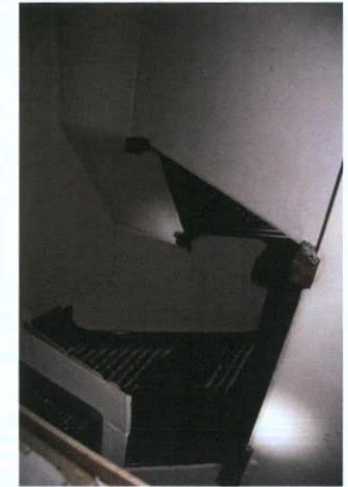

Plate 68: F-9 – Stairwell; view to upper floors



Plate 69: F-9 – View to south-west



Plate 70: F-9 – View to second floor landing

Interior – second floor

Room S-1: Accessed from Rooms F-9 and T-1. Stairwell accessing first and third floors. Closed-string, open-well staircase with quarter landings; nosed timber treads and timber risers with rubber contrast strips; balustrade formed of carved, ramped timber handrail, set to square-section newel posts at landings with pyramidal cappings, with heavily turned balusters set to stringer with ovolo profile to arrises; drop finials. Lath-and-plaster finish to ceiling and to soffit of rising staircase. Plaster finish to walls. Original skirting boards with ovolo profile. Screen at second floor landing separating stairwell from Room S-2 comprised of square-headed doorway set to carved timber frame with flanking, fixed four-pane windows, blinded to west, over carved timber aprons having carved timber architraves. Carpet finish to landings.

Room S-2: Central corridor on east-west axis. Downstand ribs of spine wall to east and west. Lath-and-plaster ceiling, with original moulded coving to perimeter of ceilings. Plaster finish to walls. Original timber panelled doors set to carved timber architraves on plinth blocks. Blocked-up window ope to south wall, formerly overlooking internal lightwell. Original timber skirting boards with ovolo profile. Carpet finish to floor.

Room S-3: Accessed from Room S-2. Lath-and-plaster finish to ceiling, with moulded coving to perimeter; portion of finishes lost to north-east corner, with exposed rectangular-section timber ceiling joists above on north-south axis. Plaster finish to walls; finishes missing to north-east corner, with exposed buff brick substrate below. Projecting chimney breast to north wall, original chimney piece comprised of integrated timber overmantel with rectangular panels flanking segmental-headed mirror and supporting timber, dentillated cornice, over nosed mantle, with ceramic tile to cast-iron fire surrounds; fireplace now blocked up. Replacement part-glazed timber door set to carved timber architraves on plinth blocks. Six-over-six timber sash window to east wall, having nosed internal timber sill and carved timber architrave. Original timber skirting boards with ovolo profile. Carved timber picture rail. Carpet finish to floor.



Plate 71: S-1 – View to south



Plate 72: S-1 – View to north



Plate 73: S-1 -View to north-east



Plate 74: S-1 – Detail to skirting



Plate 75: S-2 – View to east



Plate 76: S-3 – View to east



Plate 77: S-3 – View to west



Plate 78: S-3 – Detail to covings

DDC PLAN NO 15432/22
13/12/2022

Interior – second floor

Room S-4: Accessed from Room S-2. Plasterboard finish to ceiling. Plaster finish to walls. Flush chimney breast to south wall, original timber chimney piece having nosed mantle over fireplace, now blocked up. Flush timber door set to carved timber architraves on plinth blocks. Six-over-six timber sash window to east wall, having nosed internal timber sill and carved timber architrave. Rectangular-section skirting boards. Carved timber picture rail. Carpet finish to floor.

Room S-5: Accessed from Room S-2; canted bay entry to north-west. Plasterboard finish to ceiling. Plaster finish to walls. Timber panelled door set to carved timber architraves on plinth blocks. One-over-one timber sash window to west wall, having nosed internal timber sill and carved timber architrave and pelmet, previously overlooking internal lightwell; now blind. Carpet finish to floor.

Room S-6: Accessed from Room S-2. Flush chimney breast to south wall, with flush, segmental-headed chimney piece, now plastered/painted over; electrical heater within fireplace ope. Plasterboard finish to ceiling. Plaster finish to walls. Timber panelled doors to north and to entry to Room S-7 to east set to carved timber architraves on plinth blocks. One-over-one timber sash window to west wall, having nosed internal timber sill and carved timber architrave. Carpet finish to floor.



Plate 79: S-3 – Original chimney piece



Plate 80: S-4 – View to south



Plate 81: S-4 – View to east



Plate 82: S-4 – View to south-west



Plate 83: S-5 – View to south

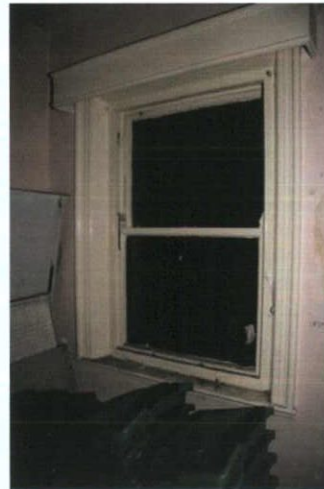

Plate 84: S-5 – View to west

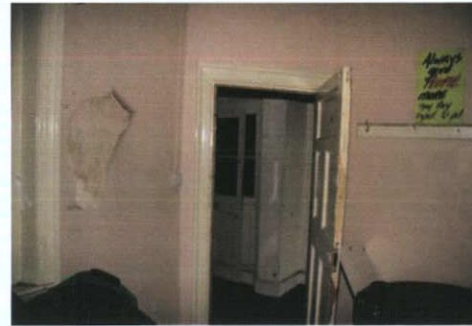

Plate 85: S-5 – View to north



Plate 86: S-6 – View to west

DDC PLAN NO 5432/22
RECEIVED: 13/12/2022

Interior – second floor

Room S-7: Accessed from Room S-6. Plasterboard finish to ceiling. Plaster finish to walls. Timber panelled door set to carved timber architraves on plinth blocks. One-over-one timber sash window to east wall, having nosed internal timber sill and carved timber architrave, previously overlooking internal lightwell; now blind. Modern shelving throughout. Carpet finish to floor.

Room S-8: Accessed from Room S-2. Lath-and-plaster finish to ceiling, with moulded coving to perimeter. Plaster finish to walls, with lining paper finish. Projecting chimney breast to north wall, original chimney piece comprised of integrated timber overmantel with rectangular panel housing oval mirror over nosed mantle supported on single carved bracket, with ceramic tile to cast-iron fire surrounds; fireplace now blocked up. Original timber panelled door set to carved timber architraves on plinth blocks. One-over-one timber sash window to west wall, having nosed internal timber sill and carved timber architrave. Original timber skirting boards with ovolo profile, partially obscured by wall covering. Carved timber picture rail. Carpet finish to floor.



Plate 87: S-6 – View to south



Plate 88: S-6 – View to east

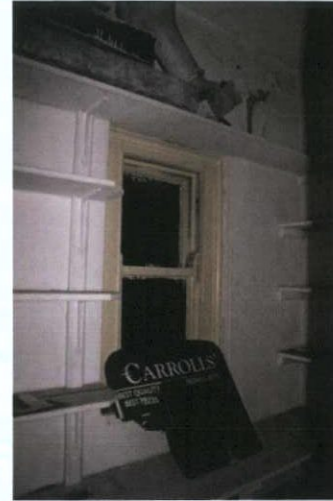

Plate 89: S-7 – View to north-east



Plate 90: S-7 – View to east



Plate 91: View into Room S-8 to north



Plate 92: S-8 – View to north



Plate 93: S-8 – View to west



Plate 94: S-8 – View to south-east

Interior – second floor

Room S-9: Accessed from Room S-2. Narrow niche without doorway to west of staircase. Plaster finish to ceiling and walls. Surface-mounted services to perimeter at high level, supported on timber rack. Vinyl finish to floor.



Plate 95: S-8 – Timber chimney piece



Plate 96: S-8 – Carved timber architrave and skirting board



Plate 97: S-8 – Detail to coving

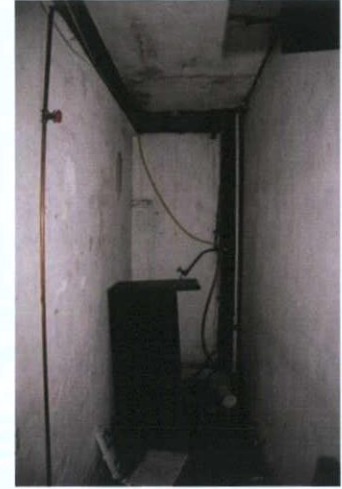

Plate 98: S-9 – View to north

Interior – third floor

Room T-1: Accessed from Room S-1. Stairwell accessing lower floors. Closed-string, open-well staircase with quarter landings; nosed timber treads and timber risers; balustrade formed of carved, ramped timber handrail, set to square-section newel posts at landings with pyramidal cappings, with heavily turned balusters set to stringer with ovolo profile to arrises; drop finials. Lath-and-plaster finish to ceiling and to soffit of rising staircase. Stairwell continues additional half-flight and balustrade returns to west, forming guarding at upper landing alongside steel door accessing flat roof. Double-pitched cast-iron rooflight with ridge on north-south axis spanning full width of Room T-1, with wire screen fixed internally. Plaster finish to walls. Original skirting boards with ovolo profile. Screen at second floor landing separating stairwell from Room T-2 comprised of square-headed doorway set to carved timber frame with flanking, fixed four-pane windows over carved timber aprons having carved timber architraves. Original timber floorboards to landings.

Room T-2: Central corridor on east-west axis. Downstand nibs of spine wall to east and west. Lath-and-plaster ceiling, with original moulded coving to perimeter of ceilings. Plaster finish to walls; east wall with access into Room T-3 possessing modern doorway comprised of timber screen with sidelights of opaque glazing. Original timber panelled doors set to carved timber architraves on plinth blocks. Blocked-up window open to south wall, formerly overlooking internal lightwell. Original timber skirting boards with ovolo profile. Timber floorboards.



Plate 99: T-1 – View to third floor landing to south



Plate 100: T-1 – View to north-west



Plate 101: T-1 – View to south-east



Plate 102: View to south-west



Plate 103: T-1- Rooflight over stairwell



Plate 104: T-1 – View to open-well staircase to lower floors



Plate 105: T-2 – View to west



Plate 106: T-2 – Blocked-up window opening to south wall

Interior – third floor

Room T-3: Accessed from Room T-2. Central downstand bressummer on east-west axis. Lath-and-plaster finish to ceiling, with moulded coving to perimeter and north side of bressummer, except to south wall. Plaster finish to walls. Projecting chimney breast to north wall, original chimney piece comprised of integrated timber overmantel with oval mirror and supporting timber, dentillated cornice, over nosed mantle supported on single carved bracket; fireplace now blocked up. Replacement part-glazed timber door set to modern timber screen with opaque glazing to sidelights. Three-over-six timber sash windows to east wall, having nosed internal timber sill and carved timber architrave. Single window ope to west wall, now blinded with nosed internal timber sill and carved timber architrave, formerly overlooking internal lightwell. Timber skirting boards with chamfered edge profile; replacement timber skirting boards to south wall. Hardboard finish to floor.

Room T-4: Accessed from Room T-2. Flush chimney breast to south wall, with elongated, segmental-headed fireplace ope having flat plastered surrounds. Plasterboard finish to ceiling. Plaster finish to walls. Timber panelled doors to north and to entry to Room T-5 to east set to carved timber architraves on plinth blocks. One-over-one timber sash window to west wall, having nosed internal timber sill and carved timber architrave. Timber skirting boards with chamfered edge profile. Original timber floorboards under later floor finishes



Plate 107: T-2 – View to east into Room T-3



Plate 108: T-3 – View to east



Plate 109: T-3 – View to south



Plate 110: T-3 – View to north

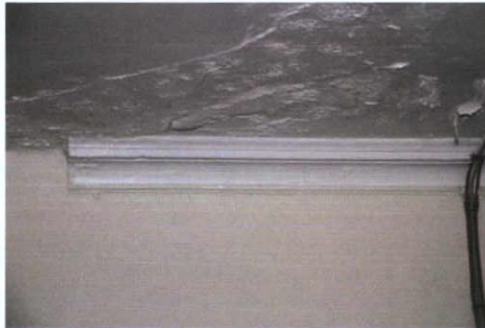

Plate 111: T-3 – Remnant of original coving



Plate 112: T-4 – View to west



Plate 113: T-4 – View to south



Plate 114: T-4 – Original floorboards under later flooring

Interior – third floor

Room T-5: Accessed from Room T-4. Modern plaster to finish on wire mesh substrate, with simple moulded coving to perimeter. Plaster finish to walls. Timber panelled door set to carved timber architraves on plinth blocks. One-over-one timber sash window to east wall, having nosed internal timber sill and carved timber architrave, overlooking internal lightwell. Timber floorboards.

Room T-6: Accessed from Room T-2. Plasterboard finish to ceiling. Plaster finish to walls, with wallpaper finish over. Original timber panelled door set to carved timber architraves on plinth blocks. Timber sash window to west wall, now blind, having nosed internal timber sill and carved timber architrave. Timber skirting boards with chamfered edge profile. Timber floorboards. Sanitaryware throughout.

Room T-7: Accessed from Room T-2. Lath-and-plaster finish to ceiling, with moulded coving to perimeter. Plaster finish to walls, with wallpaper finish over. Projecting chimney breast to north wall, original chimney piece comprised of integrated timber overmantel with rectangular panel housing oval mirror over nosed mantle supported on single carved bracket, with ceramic tile to cast-iron fire surrounds; fireplace now blocked up. Original timber panelled door set to carved timber architraves on plinth blocks. One-over-one timber sash window to west wall, having nosed internal timber sill and carved timber architrave. Timber skirting boards with chamfered edge profile. Carved timber picture rail. Timber floorboards.



Plate 115: T-4 – View to east towards Room T-5



Plate 116: T-5 – View to east

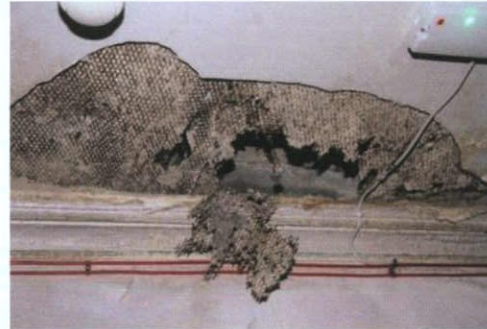

Plate 117: T-5 - Coving



Plate 118: T-6 – View into Room T-6 from Room T-2



Plate 119: T-6 – View to west



Plate 120: T-6 – View to east



Plate 121: T-7 – View to north



Plate 122: T-7 – View to west

Interior – third floor

Room T-8: Accessed from Room T-2. Narrow niche without doorway to west of staircase. Plaster finish to ceiling and walls. Timber floorboards.



Plate 123: T-7 – View to north-east

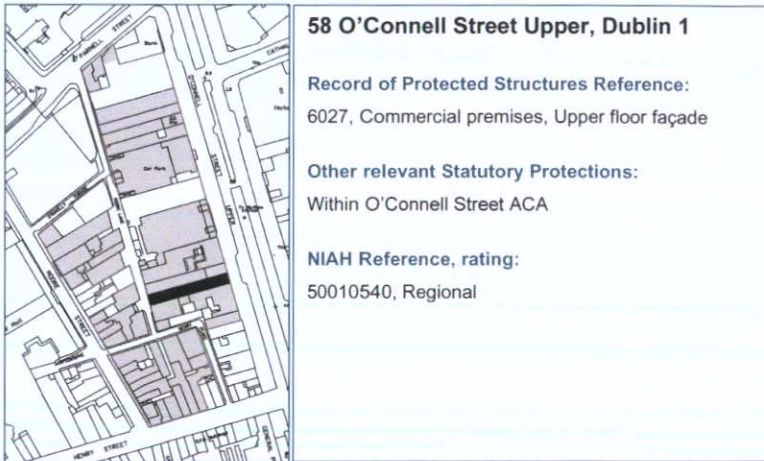

Plate 124: T-8 – View to north

EIAR Chapter 15 Cultural Heritage (Architectural)

Dublin Central Project – Site 2 & No.61 O'Connell Street Upper

Appendix 15.11 Building inventory, record and description for No.58 O'Connell Street Upper



58 O'Connell Street Upper, Dublin 1

Record of Protected Structures Reference:
6027, Commercial premises, Upper floor façade

Other relevant Statutory Protections:
Within O'Connell Street ACA

NIAH Reference, rating:
50010540, Regional

Proposed Building Site

Site 2ab

Panning history

Existing façade to be removed and rebuilt salvaging as much original material as possible, remainder of structure scheduled for demolition.

Outline building description

Four-storey, three-bay building faced with red brick laid in Flemish bond, above which is a dormer attic storey. The shopfront is a replacement, though with surviving moulded granite sill course above. The windows are framed with cut granite and are single-pane timber sliding sashes. Between first- and second-floor windows there is a bracketed cornice above the central window above which is a shield bearing the monograph JGC for J & G Campbell, above which is a swag, while to left and right are granite panels bearing rosettes. A granite cornice projects above the top-floor windows, above which is a brick blocking course.

At lower ground floor level there are extensive brick vaults surviving from 1873 when they were built for a wine and spirit merchant.

Occupancy

Occupied.



Plate 1: Front façade, 58 O'Connell Street Upper

DDC PLAN NO 5432/22
12/2022

BUILDING HISTORY

Number 58 O'Connell Street Upper was built in the 1750s as a private house. In about 1818 the premises were acquired by John Campbell, a grocer, wine and spirit merchant and wool factor.¹ This firm became John Campbell and Sons and then John and George Campbell and in 1858 and 1871 John Campbell served as Lord Mayor of Dublin.² In 1873 the premises were upgraded, with the addition of wine stores and stabling to the designs of Sir Thomas Drew.³

The Goad insurance plan of 1893 shows that the building to the front was four-storey, while the structures to the rear that covered the entire site were single-storey, except for a 1½-storey store on the Moore Lane frontage.⁴ The map noted that there was a brick arched basement in the central part of the site. The occupier was noted as J & G Campbell, wine and grocery stores.

The property was destroyed in the second battle of O'Connell Street in July 1922 and was rebuilt in the 1920s to the designs of R H Byrne.⁵ The 1926 edition of the Goad insurance plan shows that the building at the front had been replaced with a 4½-storey L-shaped building.⁶ The structures at the rear were mostly the same as in 1893, though the 1½-storey section on Moore Lane had been replaced by a single-storey building with a concrete roof. The occupier of the building was the same in 1926 as in 1893 and the brick arched basement was again noted.

J & G Campbell remained in occupation until the 1960s, with offices on the upper floors.⁷ The ground-floor unit was occupied by Marlowe Cleaners until around the turn of the century and it has been occupied by Carroll's since about 2008.⁸



Figure 1: Elevation of 58 Sackville Street Upper from Shaw's Directory of 1850



Figure 3: 58 O'Connell Street Upper, 1969



Figure 2: 28 Sackville Street c1890 (Irish Architectural Archive)

¹ Wilson's *Dublin Directory*, 1818 to 1822.

² Mary Clark, 2016, *The Dublin Civic Portrait Collection*, Four Courts Press, Dublin, p. 136.

³ Dictionary of Irish Architects, www.dia.ie.

⁴ Goad, Charles, *Insurance Plan of the City of Dublin*, 1893, sheet 4

⁵ *Freemans Journal*, 7th July 1922; Dictionary of Irish Architects, www.dia.ie.

⁶ Goad, Charles, *Insurance Plan of the City of Dublin*, 1926, sheet 4

⁷ *Thom's Directory*, 1921 to 1965.

⁸ *Thom's Directory*, 1960 to 2012.

FLOOR PLANS



Figure 4: Plan at basement level

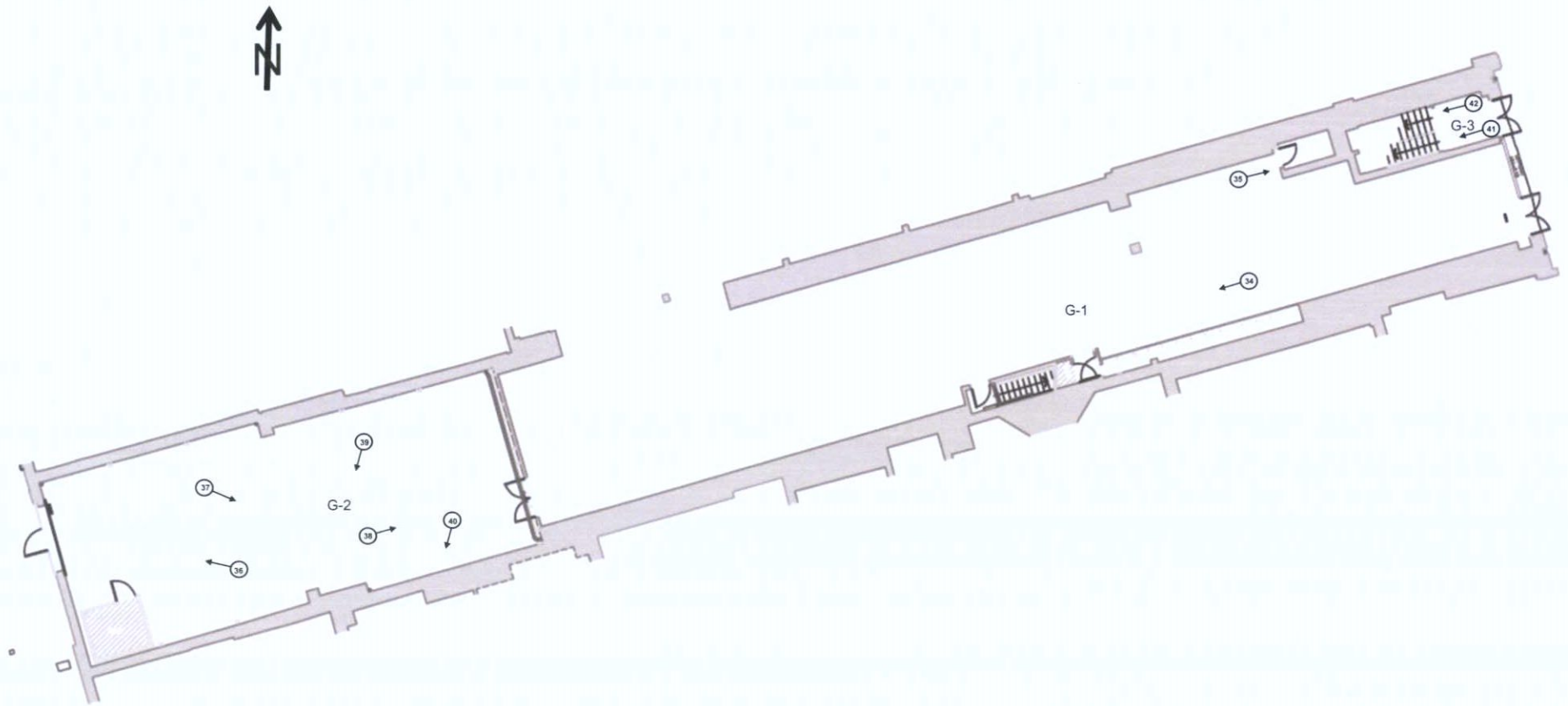

Figure 5: Plan at ground floor level

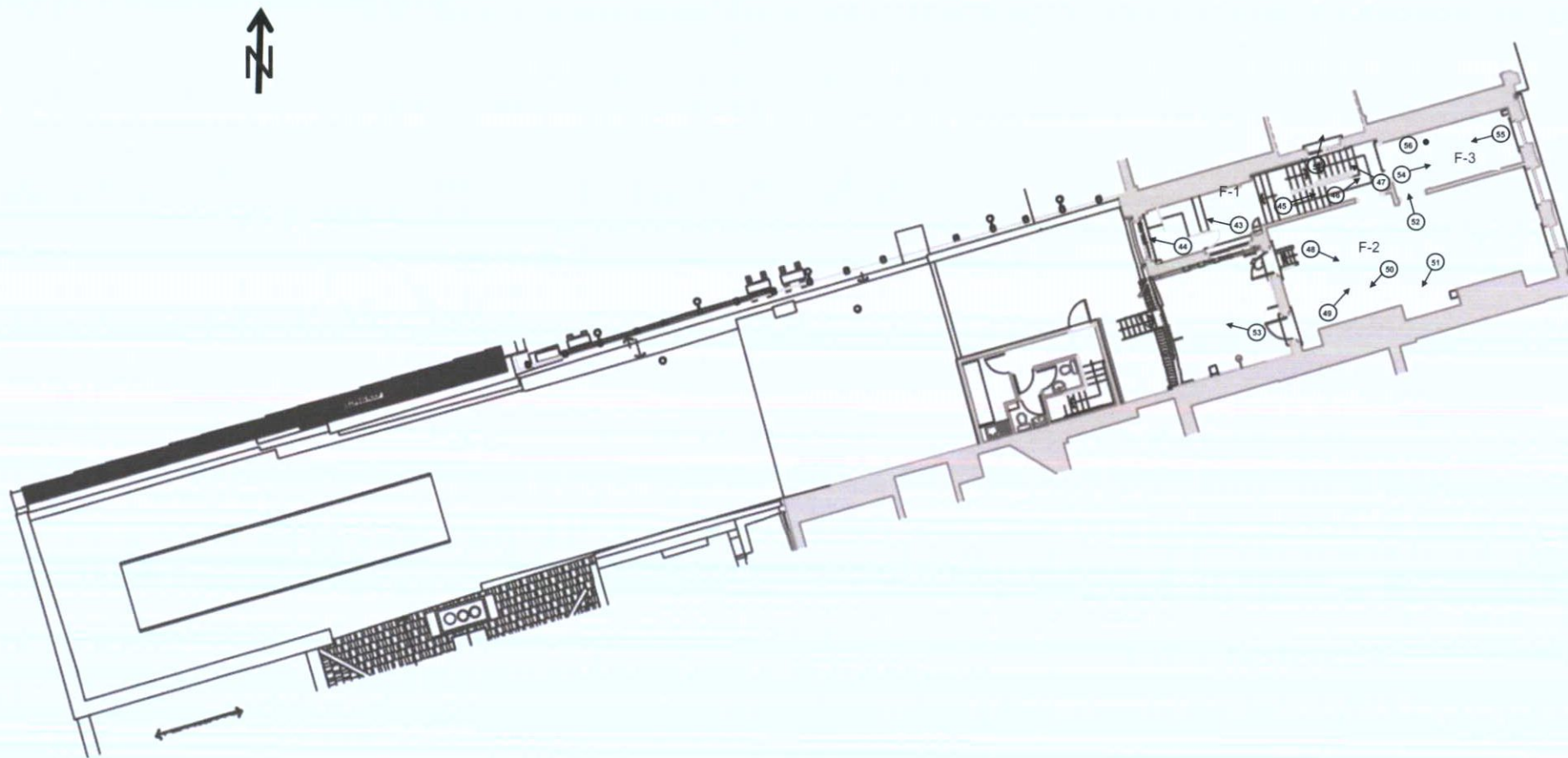

Figure 6: Plan at first floor level

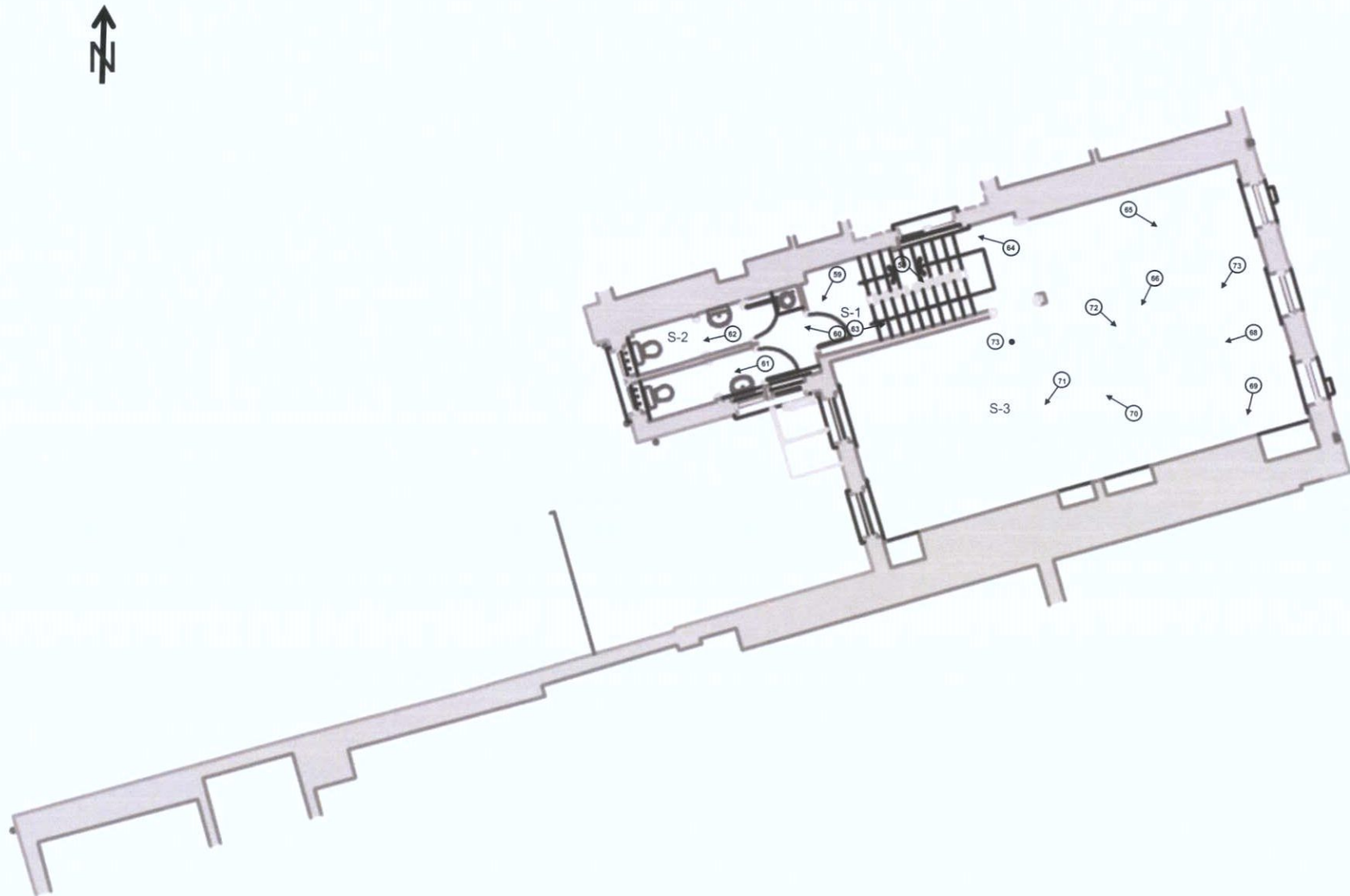

Figure 7: Plan at second floor level

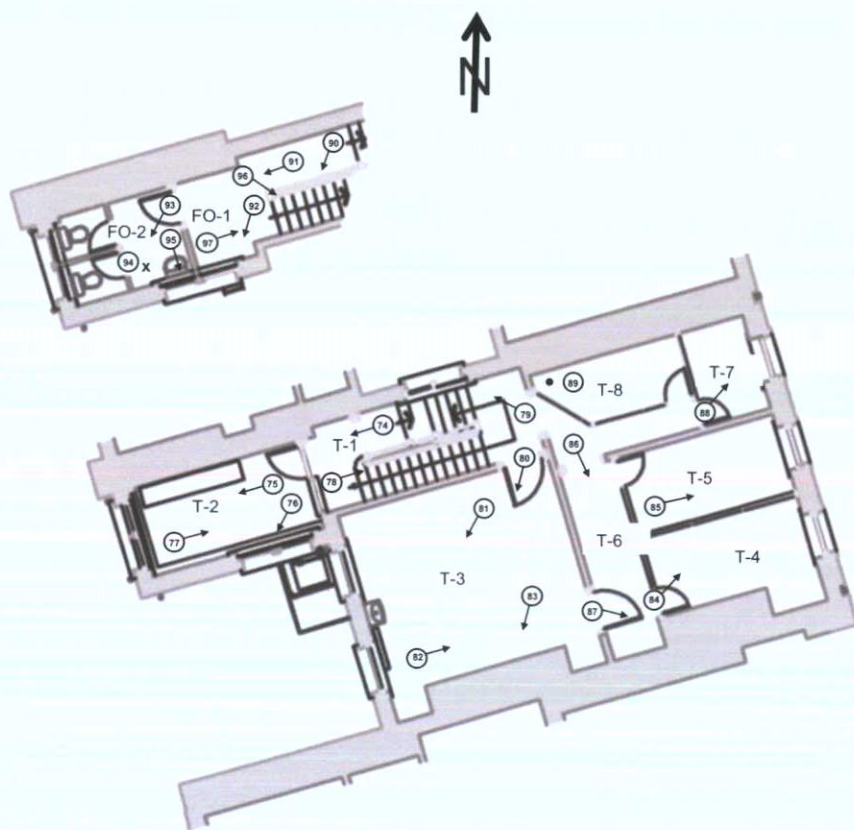

Figure 8: Plan at third floor level

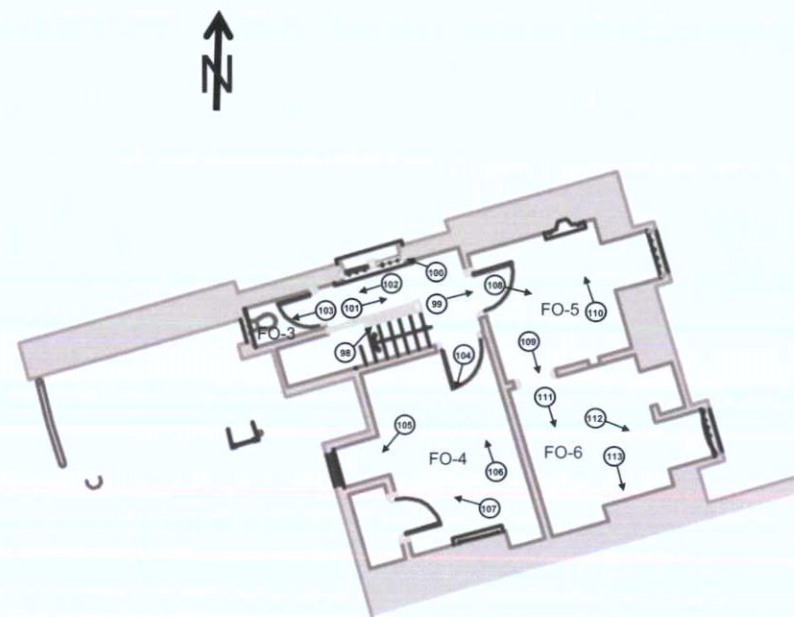

Figure 9: Plan at fourth floor level

BUILDING SURVEY

Exterior

Two-bay, four-storey-over-basement-with-dormer-attic attached building; full-height return to rear. Single pitches to east and west having copper-clad dormer windows, with raised flat roof to centre plan. Rendered chimneystack to south-west and red brick chimneystacks to south-east and to north. Granite copings over red brick blocking course, surmounting projecting cut granite cornice; cut granite string course at third floor level. One-over-one timber sash windows to all floors, having carved granite surrounds and matching sills. Red brick panelled aprons to third floor windows; panelled granite window aprons to second floor, with decorative rosettes, flanking decorative plaque with swags over corniced hood moulding set to central, first floor window; plaque bearing inscription, "JGC." Modern shop front, with original granite plat band over.

Granite coping over cementitious render to rear (west) elevation. Square-headed window openings with mix of timber sashes and uPVC casement windows throughout. Two-storey extensions to rear, flat roofs.

Rear structure facing onto Moore Lane is flat-roofed and is faced in red brick laid in Flemish bond, with stucco plat band having projecting cornice, with inscription, "J & G. CAMPB—" surviving. Part of the face of the brickwork has been cut back to facilitate a sliding steel door closing a vehicular opening.

Mix of cast-iron and uPVC rainwater goods.

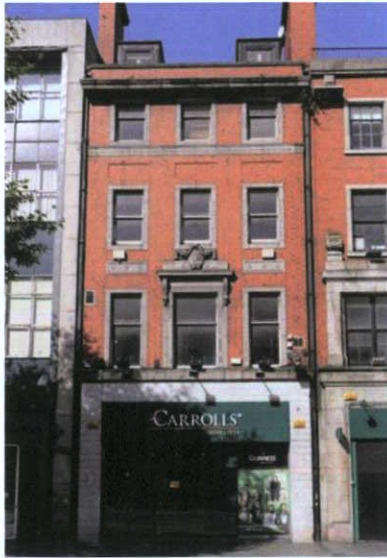

Plate 2: Front elevation



Plate 3: Elevation at second- and third-floor levels



Plate 4: Elevation at first-floor level



Plate 5: Detail of monogram over first-floor window



Plate 6: Shopfront



Plate 7: Rear façade on Moore Lane



Plate 8: Rear elevation of main building

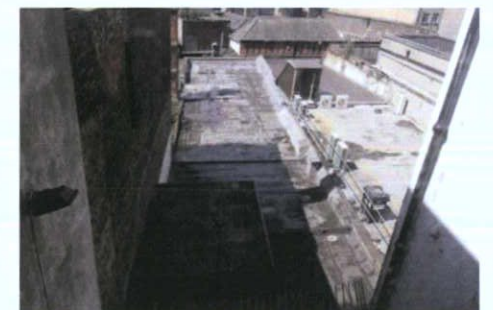

Plate 9: Roof over area at rear

DDC PLAN NO 5432/22
12/2022

Interior – basement

Room B-1: Accessed from Rooms B-2, B-3, and B-4. Original chimney breast to south wall legible on plan. Modern staircase rising to ground floor, with soffit exposed to room below. Modern plaster finish to ceiling, supported by downstand, plastered bressummers on east-west axis with perpendicular crossbraces. Walls finished with modern plaster to west and east walls, and with modern tongue-and-groove timber cladding to north and south walls. Modern timber doors and flat timber architraves. Ceramic tile skirting to localised area to north-west, also having tongue-and-groove cladding to ceiling. Modern timber presses lining walls throughout. Modern cast-iron clerestory lights to east wall. Floors finished in hardboard and ceramic tile. Surface-mounted services and ductwork throughout.

Room B-2: Accessed from Room B-1. Located within former basement well, now under public path above. Shower room. Ceiling finished in corrugated sheeting, with cast-iron frame over supporting glass block lightwell from public path. Modern tongue-and-groove timber panelling to walls. Modern shower partitions throughout. Modern timber doors and flat timber architraves. Ceramic tile finish to floor.

Room B-3: Accessed from Room B-1. Located within former basement well, now under public path above. Sauna room. Modern tongue-and-groove timber panelling to ceilings and walls. Evidence of plastered substrate to east wall. Ceramic tile finish to floor.



Plate 10: B-1 – View to east

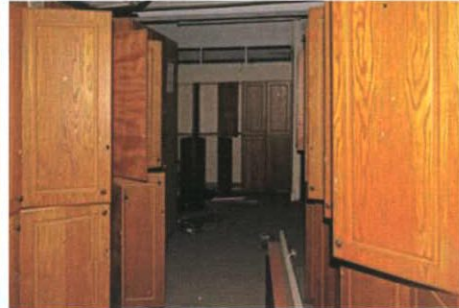

Plate 11: B-1 – View to west



Plate 12: B-1 – View to north



Plate 13: B-1 – View to south-east



Plate 14: B-1 – View to west



Plate 15: B-2 – View to east



Plate 16: B-2 – Ceiling; public path above



Plate 17: B-3 – View to east

Interior – basement

Room B-4: Accessed from Rooms B-1, B-5 and B-9. Original chimney breast to south wall legible on plan. Modern plaster finish to ceiling, supported by downstand, plastered bressummers on north-south axis, with one located under original rear elevation to west. Modern plastered finish to walls; plasterboard to timber stud partitions to east, clad over in mirrors and modern joinery. Modern timber doors and flat timber architraves. Elliptical-headed opening giving access to Room B-9. Modern timber skirting boards. Modern cast-iron clerestory lights to partition to east. Modern Linoleum finish to floors. Surface-mounted services.

Room B-5: Accessed from Rooms B-4, B-6, B-9 and B-10. Barrell-vaulted ceiling, springing from south wall, with centre point of arch at junction with north party wall; comprised of painted brick. Most walls finished in modern plaster; timber stud partition to portion of the north wall, finished in plasterboard. Modern timber skirting boards. Change in floor levels between Rooms B-4, B-6 and B-9. Surface-mounted services.

Room B-6: Accessed from Rooms B-5 and B-10. Barrell-vaulted ceiling, springing from south wall, with centre point of arch at junction with north party wall; comprised of painted brick. Most walls finished in modern plaster; timber stud partition to portion of north wall and to west wall, finished in plasterboard. Modern timber skirting boards. Change in floor levels between Rooms B-5 and B-10. Surface-mounted services.

Room B-7: Accessed from Room B-10. Barrell-vaulted ceiling, springing from south wall, with centre point of arch at junction with north party wall; comprised of painted brick. Trap door in ceiling to west, having cast-iron frame with tongue-and-groove hatch enclosure over. Walls comprised of rubble stonework, with limewash finish. Timber stud partition to east finished in plasterboard to east side, forming enclosure to Room B-6; exposed studs to Room B-7. Brick finish to floor. Surface-mounted services and ductwork.



Plate 18: B-4 – View to south-west



Plate 19: B-4 – View to east



Plate 20: B-4 – View to west into Room B-9



Plate 21: B-5 – View to east

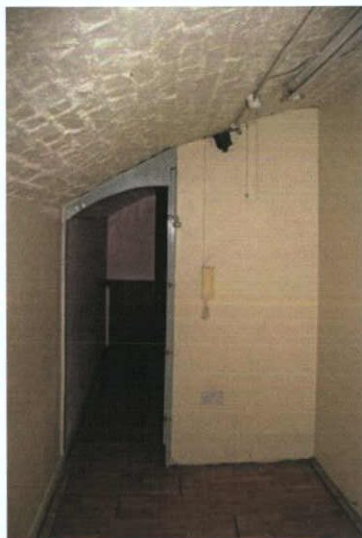

Plate 22: B-6 – View to west

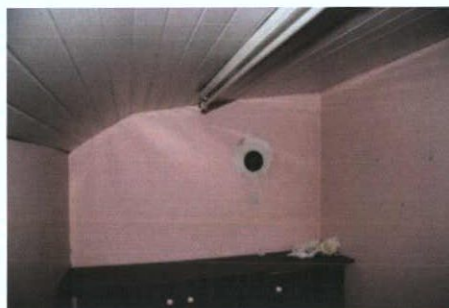

Plate 23: B-6 – View to west



Plate 24: B-7 – View to east



Plate 25: B-7 – Timber hatch to ceiling

Interior – basement

Room B-8: Accessed from Room B-9. Barrell-vaulted ceiling, springing from east and west walls finished in modern plaster. Walls finished in modern plaster; timber stud partition to north finished in plasterboard. Built-in press to west, finished internally with ceramic tile. Modern timber doors and architraves; modern timber skirting boards. Modern Linoleum finish to floors. Surface-mounted services.

Room B-9: Accessed from Rooms B-4, B-5, B-8 and B-10. Barrell-vaulted ceiling, springing from north and south walls, continuous with walls, comprised of rubble stonework finished in modern paint. Timber stud partition to south finished in plasterboard. Modern timber doors and architraves; modern plant-on dado rail. Modern timber floorboards; change of floor level between Rooms B-4, B-5 and B-10. Surface-mounted services.

Room B-10: Accessed from Rooms B-9 and B-11. Barrell-vaulted ceiling, springing from north and south walls, continuous with walls, comprised of rubble stonework finished in modern paint; south wall clad in mirrors. Low round-headed archways forming entrances to corridor to the north, Room B-9 and niche to east. Modern timber skirting boards. Modern Linoleum finish to floors. Surface-mounted services.

Room B-11: Accessed from Room B-10. Former wine stores. Barrell-vaulted ceiling, springing from north and south walls, comprised of brick finished in modern paint. Walls comprised of rubble stonework, finished in limewash and modern paint. Brick partitions to west on north-south axis with two-tier storage; low level formed of segmental-headed brick arches. Timber door to east wall set to cut timber frame, rick finish to floor. Surface-mounted services.

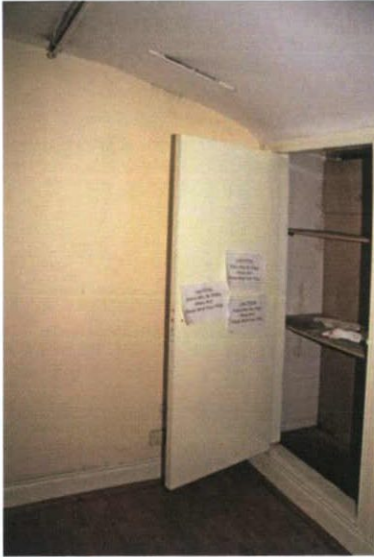

Plate 26: B-8 – View to north-west

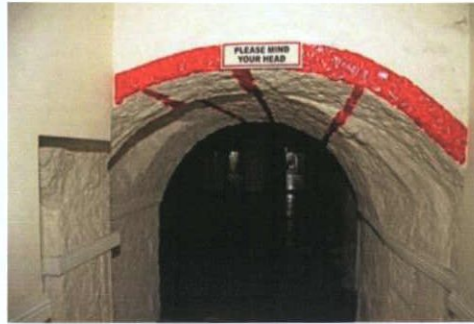

Plate 27: B-9 – View to west

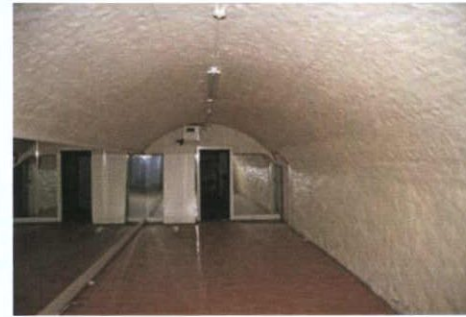

Plate 28: B-10 – View to west

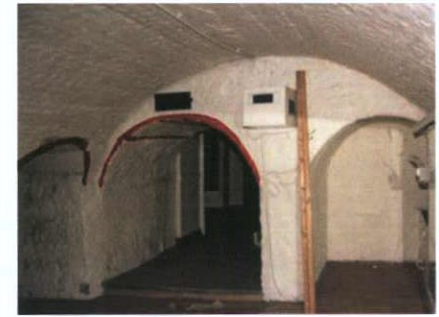

Plate 29: B-10 – View to east

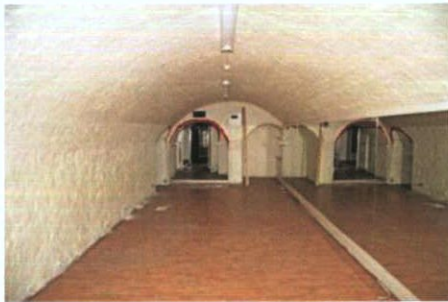

Plate 30: B-10 – View to east



Plate 31: B-11 – View to west into Room B-11



Plate 32: B-11 – View to north-west



Plate 33: B-11 – View to east

Interior – ground floor

Room G-1: Accessed from Room G-2 and external entrance from O'Connell Street Upper. Open-plan space formed of squared columns supporting ceiling at regular intervals; suspended ceiling finished with ceiling tiles. Plasterboard finishes to walls, with some commercial timber fit-out linings. Flush timber doors and flat timber architraves. Ceramic tile finish to floor.

Room G-2: Accessed from Room G-1 and from Number 57 O'Connell Street Upper to north. Suspended ceiling finished with ceiling tiles. Timber stud partition to east forming enclosure to Room G-1, finished with plasterboard on east side; exposed studs to Room G-2. Modern plaster finish to north wall. South wall supported by engaged brick piers; remaining walls comprised of painted brickwork and some cementitious render to west; west wall comprised of painted brickwork with steel roller shutter enclosing access from Moore Lane. Flush timber doors and flat timber architraves. Ceramic tile finish to floor. Surface-mounted services.

Room G-3: Accessed from external entrance from O'Connell Street Upper. Entry lobby and stairwell accessing lower and upper floors. Closed-string, dog-leg stairwell with elongated flight rising to first floor; treads and risers finished in carpet; steel contrast strips to lower flight. Balustrade to lower flight enclosed with plasterboard, surmounted by carved timber handrail with square-section, timber panelled newel post on plinth blocks having pyramidal timber capping. Additional carved timber handrail affixed to south wall. Tongue-and-groove timber cladding to ceiling to entry lobby. Plasterboard finish to ceiling over stairwell. Modern plaster finishes to walls. Round-headed archway between lobby and stairwell springing from timber panelled pilasters on plinth blocks with Doric timber capitals. Original timber skirting board / stringer with ovolo and beaded profile. Modern carved timber dado rail. Flush timber door and flat timber architrave to lower level. Ceramic tile finish to floor; carpet finish to upper flight of stairs. Surface-mounted services.



Plate 34: G-1 – View to west



Plate 35: G-1 – View to east



Plate 36: G-2 – View to west



Plate 37: G-2 – View to north-east



Plate 38: B-2 – View to east



Plate 39: B-2 – View to south



Plate 40: B-2 – Detail to junction at ceiling



Plate 41: G-3 – View to west

Interior – first floor

Room F-1: Accessed from Rooms G-3 and S-1. Rising stairwell to upper floors. Open-string, dog-leg stairwell; squared treads and risers finishes in timber; steel contrast strips. Carved timber tread ends. Balustrade comprised of carved timber handrail with square-section, timber panelled newel post on plinth blocks having pyramidal timber capping and infill of turned timber balusters; drop finials. Plaster finish to ceilings; lath-and-plaster finish to soffit of rising staircase. Plaster finish to walls. Enclosure to half-landing formed by high-level timber-clad plant enclosure and timber-clad half-height room divider. Square-headed window ope to west wall, having multi-pane uPVC casement window with carved timber architrave and squared internal timber sills. Square-headed window opening to south wall. Square-headed window opening to north wall facing into lightwell formed with Number 57 O'Connell Street Upper. Original timber skirting boards with ovolo profile. Carved timber door architraves. Linoleum finish to floors. Surface-mounted services.

Room F-2: Accessed from Rooms F-1 and F-3. Projecting chimney breasts to south wall, now blocked-up. Downstand nib of central spine wall, with vertical nib to north, forming large opening between former front and rear rooms, now one single space. Plaster finish to ceiling, with moulded coving to perimeter and to flat ceiling, forming ceiling panels. Plaster finish to walls; now clad with mirrors framed in modern timber architraves. Carved timber door architraves. One-over-one timber sash windows to east wall, having carved timber architraves and squared internal timber sills. Square-headed window opes to west wall having uPVC casement windows with carved timber architraves and squared internal timber sills. Carved timber picture rail. Original timber skirting boards with ovolo profile. Linoleum finish to floors.



Plate 42: F-1 – View to west

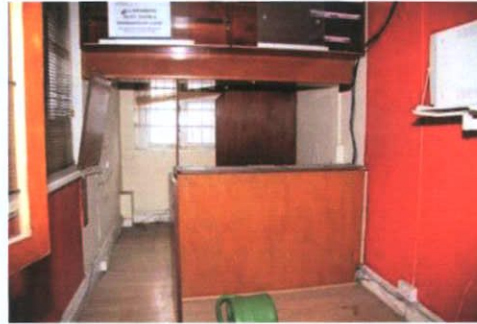

Plate 43: F-1 – View to west



Plate 44: F-1 – View to west



Plate 45: F-1 – View to east



Plate 46: F-1 – View to east



Plate 47: F-1 – Detail to balustrade



Plate 48: F-2 – View to north-east



Plate 49: F-2 – View to east

Interior – first floor

Room F-3: Accessed from Rooms F-1 and F-2. Downstand nib of central spine wall over large opening between front and rear portions of room. Plaster finish to ceiling, with moulded coving to perimeter. Plaster finish to walls; now clad with mirrors to north wall, framed in modern timber architraves. Carved timber door architraves. One-over-one timber sash window to east wall, having carved timber architraves and squared internal timber sill. Carved timber pelmet over window. Carved timber picture rail. Original timber skirting boards with ovolo profile. Linoleum finish to floors.



Plate 50: F-2 – View to west

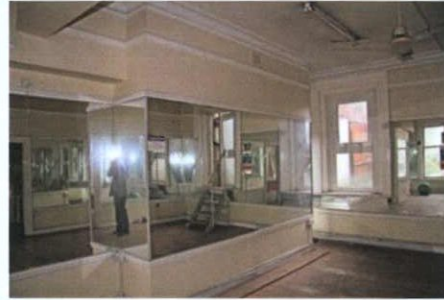

Plate 51: F-2 – View to south-west

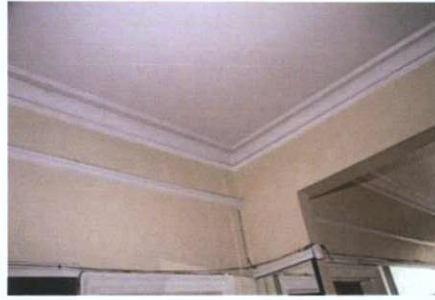

Plate 52: F-2 – View to ceiling



Plate 53: F-2 – View over rear extension from west window



Plate 54: F-3 – View to east



Plate 55: F-3 – View to east



Plate 56: F-3 – Detail to coving



Plate 57: F-1 – View through window in north wall to lightwell formed with Number 57 O'Connell Street Upper

Interior – second floor

Room S-1: Accessed from Rooms G-3 and S-1. Rising stairwell to upper floors. Open-string, dog-leg stairwell; squared treads and risers finished in timber; steel contrast strips. Carved timber tread ends. Balustrade comprised of carved timber handrail with square-section, timber panelled newel post on plinth blocks having pyramidal timber capping and infill of turned timber balusters; drop finials. Plaster finish to ceilings; lath-and-plaster finish to soffit of rising staircase. Plaster finish to walls; plasterboard finish to timber stud partition forming enclosure to Room S-2 to west. Square-headed window opening to north wall, having paired one-over-one timber sash windows with timber mullion, having carved timber architrave and squared internal timber sills; facing into lightwell formed with Number 57 O'Connell Street Upper. Original timber skirting boards with ovolo profile. Carved timber door architraves. Linoleum finish to floors. Surface-mounted services.

Room S-2: Accessed from Room S-1. Toilet enclosure to half-landing. Plaster finish to ceiling. Plaster finish to walls; plasterboard finish to timber stud partitions forming enclosure to Room S-1 to east and forming non-original toilet cubicles to west. Square-headed window opens to west wall to each cubicle, having uPVC casement windows with carved timber architrave and squared internal timber sills. Square-headed window opening to south wall. Original timber skirting boards with ovolo profile to perimeter walls, none to non-original toilet cubicle partitions. Carved timber door architraves. Ceramic tile finish to floor. Surface-mounted services. Sanitaryware throughout.



Plate 58: S-1 – Carved tread ends to rising staircase

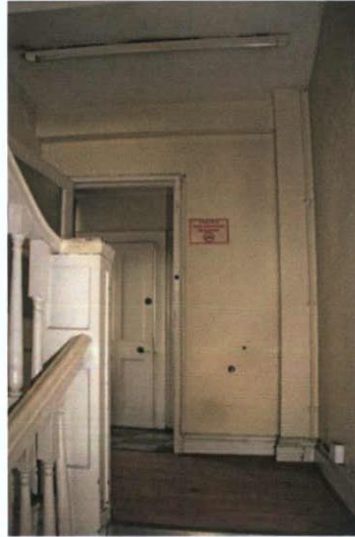

Plate 59: S-1 – View to west towards Room S-2



Plate 60: S-2 – View to west



Plate 61: S-2 – View to west

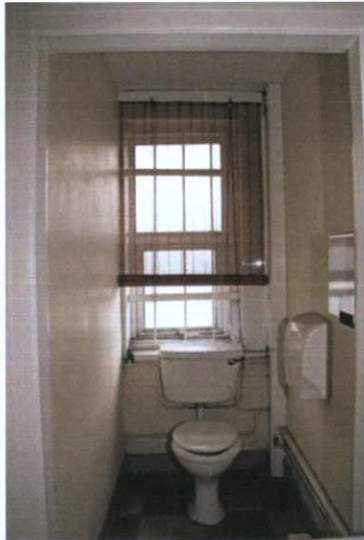

Plate 62: S-2 – View to west



Plate 63: S-1 – View to east

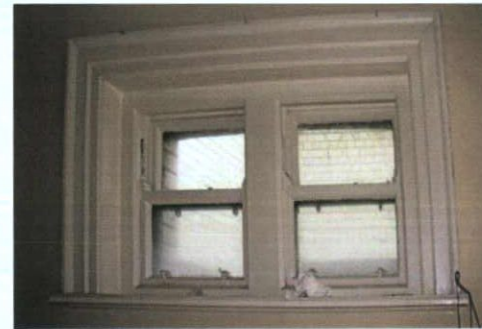

Plate 64: S-1 – View to north

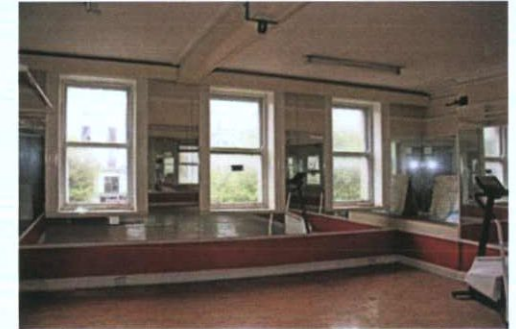

Plate 65: S-3 – View to east

Interior – second floor

Room S-3: Accessed from Room S-1. Projecting chimney breasts to south wall, now blocked-up, with central niches blocked up by timber stud enclosures. Downstand nib of central spine wall, with vertical nib to north and downstand bressummer on east-west axis bearing between spine wall and east wall, forming single, open-plan space at this level. Plaster finish to ceiling, with moulded coving to perimeter and to bressummer. Plaster finish to walls; now clad with mirrors framed in modern timber architraves. Carved timber door architraves. One-over-one timber sash windows to east wall, having carved timber architraves and squared internal timber sills. Square-headed window opens to west wall having uPVC casement windows with carved timber architraves and squared internal timber sills. Carved timber picture rail. Original timber skirting boards with ovolo profile. Linoleum finish to floors.

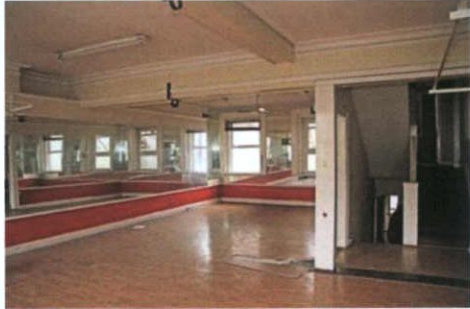

Plate 66: S-3 – View to south-west

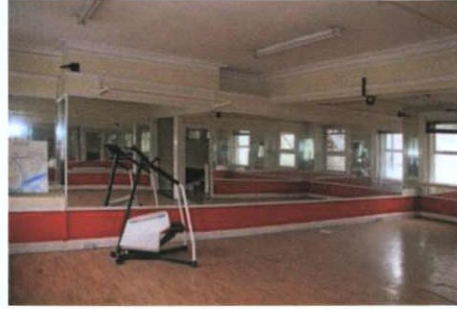

Plate 67: S-3 – View to south



Plate 68: S-3 – View to west



Plate 69: S-3 – Detail to coving to south chimney breast

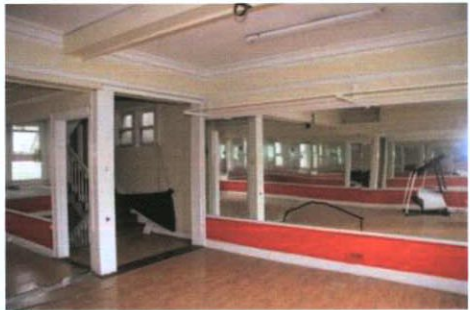

Plate 70: S-3 – View to north-west



Plate 71: S-3 – View to west

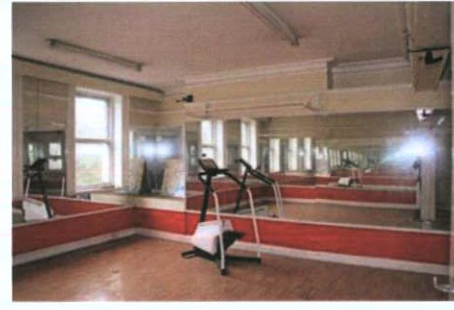

Plate 72: S-3 – View to south-east



Plate 73: S-3 – View to ceiling

Interior – third floor

Room T-1: Accessed from Rooms S-1, T-2 and FO-1. Stairwell to upper and lower floors. Open-string, dog-leg stairwell; squared treads and risers finished in carpet; steel contrast strips. Carved timber tread ends. Balustrade up to half-landing comprised of carved timber handrail with square-section, timber panelled newel post on plinth blocks having pyramidal timber capping and infill of turned timber balusters; drop finials. No balustrade from half-landing to third floor landing; only carved timber handrail affixed to north wall comprising timber stud enclosure of third and fourth floors of stairwell. Plaster finish to ceilings; lath-and-plaster finish to soffit of rising staircase. Plaster finish to walls; plasterboard finish to timber stud partition forming enclosure to Room T-2 to west and enclosing upper flight of stairs to third floor landing. Square-headed window opening to north wall, having paired one-over-one timber sash windows with timber mullion, having carved timber architrave and squared internal timber sills; facing into lightwell formed with Number 57 O'Connell Street Upper. Original timber skirting boards with ovolo profile. Carved timber door architraves. Carpet finish to floors.

Room T-2: Accessed from Room S-1. Enclosure to half-landing. Plaster finish to ceiling. Plaster finish to walls; plasterboard finish to timber stud partitions forming enclosure to Room S-1 to east. Square-headed window opens to west wall, now blinded to interior. Square-headed window opening to south wall, having paired one-over-one timber sash windows with timber mullion, having carved timber architrave and squared internal timber sill; mild steel security grille to interior. Replacement timber skirting boards and low-level service trunking. Part-glazed timber panelled door with carved timber door architraves. Linoleum finish to floor. Surface-mounted services.

Room T-3: Accessed from Rooms T-1 and T-6. Projecting chimney breast to south wall, now blocked-up. Plaster finish to ceiling, with moulded coving to perimeter. Plaster finish to walls. Part-glazed timber panelled door with carved timber door architraves. One-over-one timber sash windows to west wall, having carved timber architraves and squared internal timber sills. Carved timber picture rail. Timber skirting boards with ovolo profile. Linoleum finish to floors. Some sanitaryware noted.



Plate 74: T-1 – View to west



Plate 75: T-2 – View to west



Plate 76: T-2 – View to south

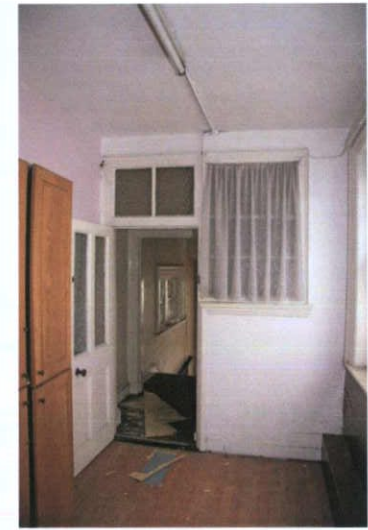

Plate 77: T-2 – View to east

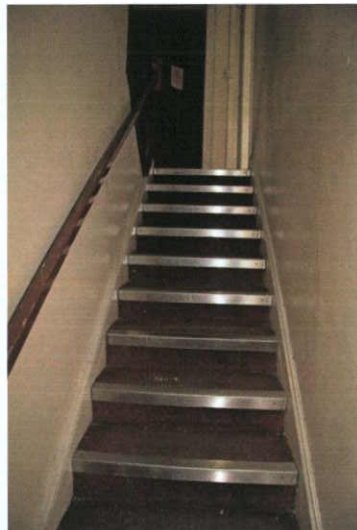

Plate 78: T-1 – View to east; timber stud enclosure to upper flights of stairwell to north (left)



Plate 79: T-1 – View to north-west; original balustrade design resumes from third floor landing to fourth floor

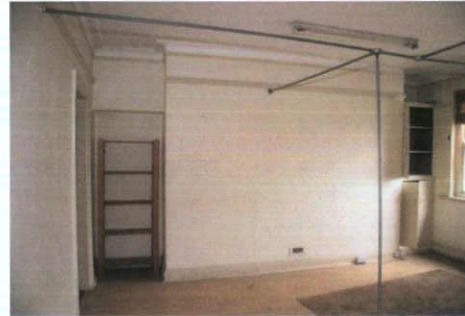

Plate 80: T-3 – View to south

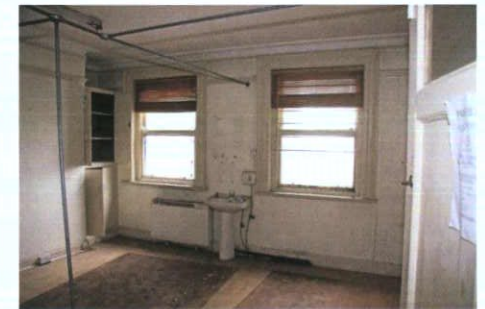

Plate 81: T-3 – View to west

Interior – third floor

Room T-4: Accessed from Rooms T-5 and T-6. Subdivision of original south-east room. Projecting chimney breast to south wall, now blocked-up and interrupted by non-original timber stud partition forming Room T-6 to west. Plaster finish to ceiling, with moulded coving to perimeter. Plaster finish to walls; low-level timber stud partitions forming enclosure to Room T-5 to north and Room T-6 to west; coving oversails top of partition; partition finished in hardboard. Flush timber door. One-over-one timber sash window to east wall, having carved timber architraves and squared internal timber sills. Carved timber picture rail. Timber skirting boards with ovolo profile. Linoleum finish to floors.

Room T-5: Accessed from Rooms T-4 and T-6. Subdivision of original south-east room. Plaster finish to ceiling, with moulded coving to perimeter. Plaster finish to east and north walls; low-level timber stud partitions forming enclosure to Room T-54 to south and Room T-6 to west; coving oversails top of partition; partition finished in hardboard. Flush timber door. One-over-one timber sash window to east wall, having carved timber architraves and squared internal timber sills. Carved timber picture rail. Timber skirting boards with ovolo profile. Linoleum finish to floors.

Room T-6: Accessed from Rooms T-1, T-3, T-4, T-5, T-7 and T-8. Subdivision of original south-east room. Projecting chimney breast to south wall, now blocked-up and interrupted by non-original timber stud partition forming Room T-4 to east. Plaster finish to ceiling, with moulded coving to perimeter. Plaster finish to walls; low-level timber stud partitions forming enclosures to Rooms T-4, T-5, T-7 and T-7 to north and east; coving oversails tops of partitions; partitions finished in hardboard. Flush timber doors; carved timber architrave to west spine wall and to north wall. timber picture rail. Timber skirting boards with ovolo profile. Linoleum finish to floors.

Room T-7: Accessed from Rooms T-6 and T-8. Subdivision of original north-east room. Plaster finish to ceiling, with moulded coving to perimeter. Plaster finish to walls; low-level timber stud partition forming enclosure to Rooms T-6 and T-8 to west; coving oversails tops of partitions; partitions finished in hardboard. Flush timber door. One-over-one timber sash window to east wall, having carved timber architraves and squared internal timber sills. Timber picture rail. Timber skirting boards with ovolo profile. Linoleum finish to floors.

Room T-8: Accessed from Room T-6. Subdivision of original north-east room. Plaster finish to ceiling, with moulded coving to perimeter. Plaster finish to walls; low-level timber stud partition forming enclosure to Rooms T-6 and T-7 to east and south; coving oversails tops of partitions; partitions finished in hardboard. Flush timber door. Timber picture rail. Timber skirting boards with ovolo profile. Linoleum finish to floors.

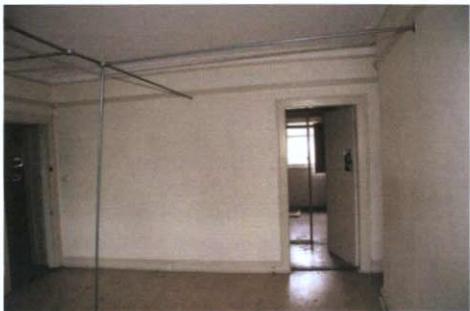

Plate 82: T-3 – View to east



Plate 83: T-3 – Detail to coving

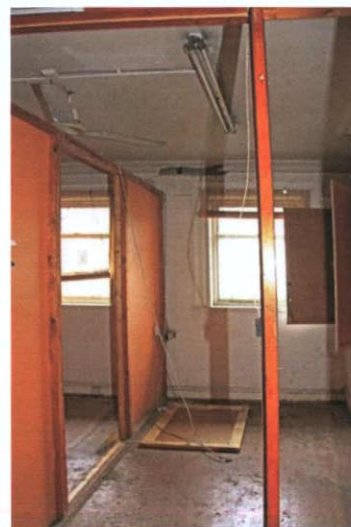

Plate 84: T-4 – View to east



Plate 85: T-5 – View to east

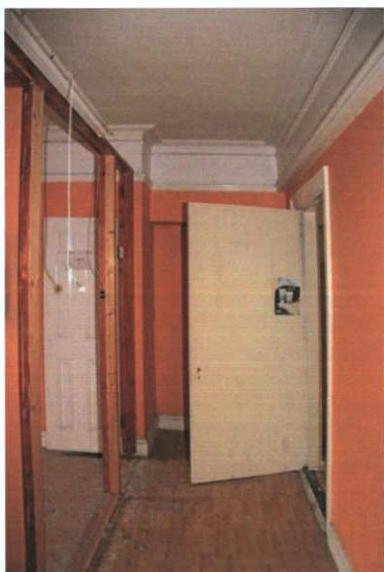

Plate 86: T-6 – View to south



Plate 87: T-6 – Detail to coving



Plate 88: T-7 – View to east



Plate 89: T-8 – Detail to coving

Interior – fourth floor

Room FO-1: Accessed from Rooms T-1 and FO-2. Stairwell to fourth floor and lower floors. Open-string, dog-leg stairwell; short flight of steps to fourth floor half-landing; squared treads and risers finished in timber; vinyl contrast strips. Carved timber tread ends. Balustrade comprised of carved timber handrail with square-section, timber panelled newel post on plinth blocks having pyramidal timber capping and infill of turned timber balusters; drop finials. Balustrade returns to west at fourth floor landing, forming guarding along corridor to Room FO-3. Plaster finish to ceilings; lath-and-plaster finish to soffit of rising staircase. Plaster finish to walls; plasterboard finish to timber stud partition forming enclosure to Room FO-2 to west. Square-headed window opening to north wall, having paired one-over-one timber sash windows with timber mullion, carved timber architrave and squared internal timber sill. Square-headed window opening to south wall, having paired one-over-one timber sash windows with timber mullion, having carved timber architrave and squared internal timber sills; interrupted by non-original partition to west. Original timber skirting boards with ovolo profile. Carved timber door architraves. Timber floorboards. Surface-mounted services.

Room FO-2: Accessed from Room FO-1. Toilet enclosure to half-landing. Plaster finish to ceiling. Plaster finish to walls; plasterboard finish to timber stud partitions forming enclosure to Room FO-1 to east and forming non-original toilet cubicles to west. Square-headed window opening to west wall to each cubicle, having one-over-one timber sash windows with carved timber architrave and squared internal timber sills. Square-headed window opening to south wall, having paired one-over-one timber sash windows with timber mullion, having carved timber architrave and squared internal timber sills; interrupted by non-original partition to east. Carved timber door architraves; flat timber architraves to modern doors to toilet cubicles. Quarry tiles to floor. Glazed ceramic tile skirting. Surface-mounted services. Sanitaryware throughout.



Plate 90: FO-1 – View to west

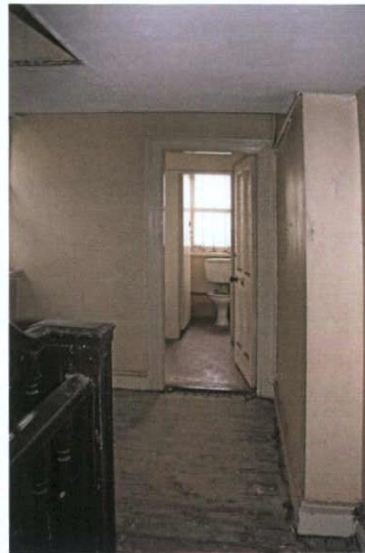

Plate 91: FO-2 – View to west

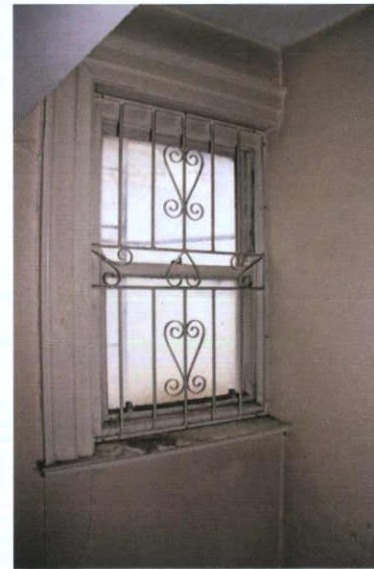

Plate 92: FO-1 – View to south; window interrupted by non-original partition forming Room FO-2 to west



Plate 93: FO-2- View to west



Plate 94: FO-2 – Quarry tile

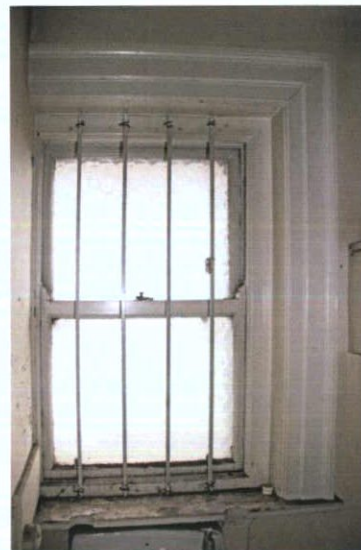

Plate 95: FO-2 – View to west



Plate 96: FO-1 – View to east



Plate 97: FO-1 – View to east

DDC PLAN NO 5432/22
13/12/2022

Interior – fourth floor

Room FO-3: Accessed from Room FO-1. Toilet cubicle to upper landing. Plaster finish to ceiling and to walls. Square-headed window opening to west wall, having one-over-one timber sash window with carved timber architrave and squared internal timber sill; steel security bars to interior of ope. Original timber skirting boards with ovolo profile. Flush timber door and carved timber door architraves. Timber floorboards. Surface-mounted services. Sanitaryware throughout.

Room FO-4: Accessed from Room FO-1. Plasterboard finish to ceiling, supported by downstand bressummer clad in plasterboard, and supported on projecting shallow chimney breast to south wall, now blocked up, with cast-iron chimney piece. Plaster finish to walls, with some lining paper. Square-headed window opening to west wall, forming dormer window and set within recessed niche, having one-over-one timber sash window with carved timber architrave and squared internal timber sill; steel security bars to interior of ope. Board-and-batten door enclosing eaves-level enclosure to south-west. Timber panelled door with carved timber architrave. Modern skirting boards with chamfered profile. Timber floorboards.



Plate 98: FO-1 – Detail to balustrade to fourth floor landing



Plate 99: FO-1 – View to east into Room FO-5

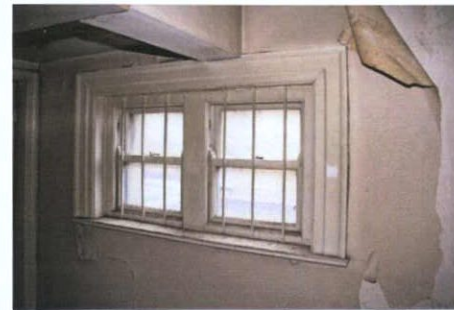

Plate 100: FO-1 – View to north

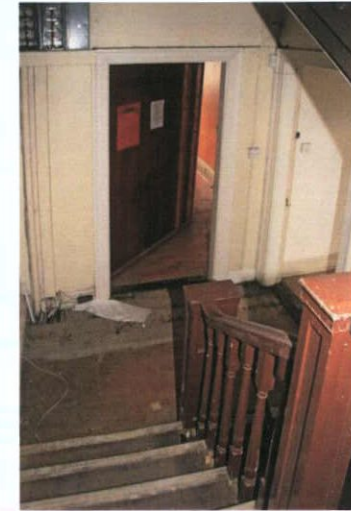

Plate 101: FO-1 – View to east towards third floor landing



Plate 102: FO-1 – View to west



Plate 103: FO-3 – View to west



Plate 104: FO-4 – View to south

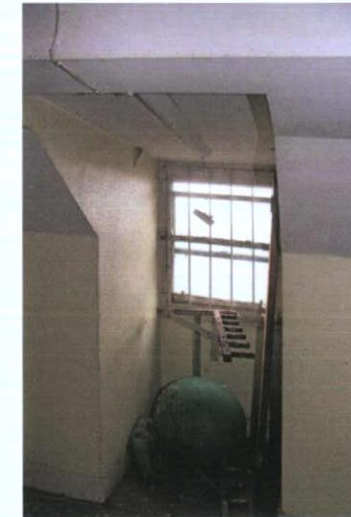

Plate 105: FO-4 – View to west; dormer window

Interior – fourth floor

Room FO-5: Accessed from Room FO-1. Plasterboard finish to ceiling, supported by downstand bulkhead clad in plasterboard, and supported on central partition and on flush chimney breast to north wall, now blocked up, with cast-iron chimney piece and cast-iron fire surround. Plaster finish to walls. Square-headed window opening to east wall, forming dormer window and set within recessed niche, having one-over-one timber sash window with carved timber architrave and squared internal timber sill. Timber panelled doors with carved timber architraves. Original skirting boards with ovolo profile. Timber floorboards. Surface-mounted services.

Room FO-6: Accessed from Room FO-5. Plasterboard finish to ceiling, supported by downstand bulkhead clad in plasterboard, and supported on central partition and on projecting chimney breast to north wall, now blocked up; ceramic tile hearth. Plaster finish to walls. Square-headed window opening to east wall, forming dormer window and set within recessed niche, having one-over-one timber sash window with carved timber architrave and squared internal timber sill. Eaves-level enclosure to north-east. Timber panelled door with carved timber architraves. Original skirting boards with ovolo profile. Timber floorboards. Surface-mounted services.



Plate 106: FO-4 – View to north

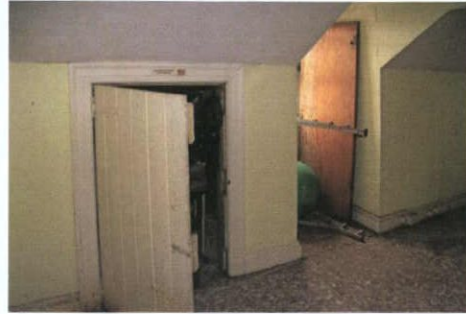

Plate 107: FO-4 – View to west



Plate 108: FO-5 – View to east



Plate 109: FO-5 – View to south into Room FO-6



Plate 110: FO-5 – View to north



Plate 111: FO-6 – View to south

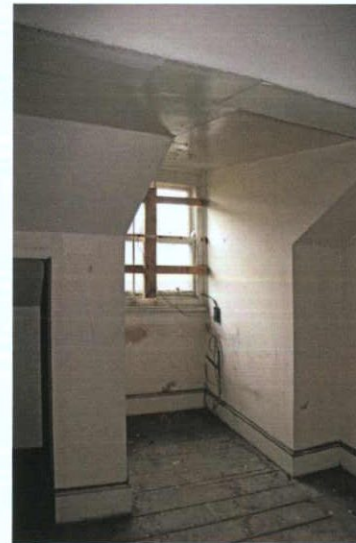

Plate 112: FO-6 – View to east; dormer window

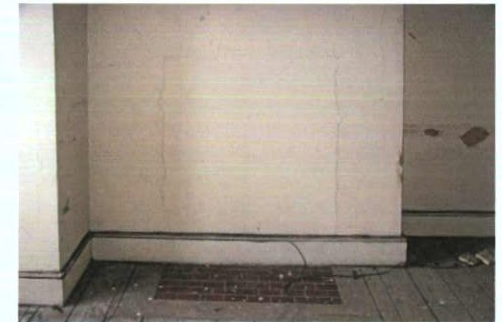

Plate 113: FO-6 – Hearth to blocked-up chimney breast to south

EIAR Chapter 15 Cultural Heritage (Architectural)

Dublin Central Project – Site 2 & No.61 O'Connell Street Upper

Appendix 15.12 Building inventory, record and description for rear buildings at

No.59 O'Connell Street Upper

Note: entirety of plot, whilst outside red line boundary, added for reference