

Potential risks arising from Demolition and Construction Works identified:

- (a) Vibration induced damage from demolition, piling and excavation works.
- (b) Physical impact from machinery and /or swing of material deliveries
- (c) General implementation of works such as landing shutters / reinforcement / steelwork deliveries in close proximity to the historic / protected structures.
- (d) Works to the historic / protected structures themselves.

### 7.3.2 Vibrations Standards

Vibration standards come in two varieties: those dealing with human comfort and those dealing with cosmetic or structural damage to buildings. In both instances, it is appropriate to consider the magnitude of vibration in terms of Peak Particle Velocity (PPV). Guidance relevant to acceptable vibration within buildings is contained in the following documents:

- British Standard *BS7385: 1993: Evaluation and measurement for vibration in buildings Part 2: Guide to damage levels from ground borne vibration* (hereinafter referred to as BS7385:1993).
- British Standard *BS5228-2: 2009 + A1: 2014: Code of practice for noise and vibration control on construction and open sites – Vibration* (hereinafter referred to as BS 5228-2 2009+A1:2014).

### 7.3.3 Impact of ground borne vibrations arising from Proposed works

Peak particle velocity (PPV) is commonly used to assess the structural response of buildings to vibration. Reference to the following documents has been made for the purposes of this assessment in order to discuss appropriate PPV limit values:

- British Standard *BS7385: 1993: Evaluation and measurement for vibration in buildings Part 2: Guide to damage levels from ground borne vibration*.
- British Standard *BS5228-2: 2009 + A1: 2014: Code of practice for noise and vibration control on construction and open sites – Vibration*
- 

BS7385-2:1993 and BS5228-2:2009+A1:2014 advise that, for soundly constructed residential property and similar structures that are generally in good repair, a threshold for minor or cosmetic (i.e. non-structural) damage should be taken as a peak component particle velocity (in frequency range of predominant pulse) of 15mm/s at 4Hz increasing to 20mm/s at 15Hz and 50mm/s at 40Hz and above for transient vibration. Where the dynamic loading caused by continuous vibration is such as to give rise to dynamic magnification due to resonance, especially at the lower frequencies where lower guide values apply, then the guide values in Table B.2 might need to be reduced by up to 50%. On a cautious basis, therefore, continuous vibration limits are set as 50% of those for transient vibration across all frequency ranges.

The documents note that minor structural damage can occur at vibration magnitudes which are greater than twice those presented in Table 5. Major damage to a building structure is possible at vibration magnitudes greater than four times the values set out in the Table. It should be noted that these values refer to the vibration at base of the building.

Historically important buildings, that are difficult to repair might require special consideration on a case by case basis, but buildings of historical importance should not be assumed to be more sensitive unless they

are structurally unsound. If a building, is in an unstable state, then it will tend to be more vulnerable to the possibility of damage arising from vibration or any other groundborne disturbance.

The vibration limit range for protected and historical buildings are equal to or up to 50% of those for light framed, depending on their structural integrity. Where no structural defects are noted, the same limit to those for light framed buildings apply. For other structures and buildings that are determined to be potentially vulnerable to vibration due to significant structural defects, a further stringent criteria has been applied for transient vibration. It is assumed that known buildings and structures of this kind, will be subject to condition surveys well in advance of the works, and any defects identified repaired. The results of conditions surveys will determine whether a building or structure is classed as “vulnerable”.

Table 5 sets out the limits as they apply to vibration frequencies below 4Hz where the most conservative limits are required. At higher frequencies, the limit values for transient vibration within Table B.2 of BS5228-2:2009+A1:2014 will apply, with similar reductions applied for continuous vibration and those for protected structures.

| Structure Type  | Allowable Vibration (in terms of PPV) at the Closest Part of Sensitive Property to the Source of Vibration, at a Frequency of 4Hz and less: |                      |
|---|---|----------------------|
|   | Transient Vibration   | Continuous Vibration |
| Reinforced or framed structures. Industrial and heavy commercial buildings              | 50mm/s  | 25mm/s               |
| Unreinforced or light framed structures. Residential or light commercial-type buildings | 15mm/s  | 7.5mm/s              |
| Protected and Historic Buildings <sup>*Note 1</sup>                                     | 6mm/s – 15mm/s  | 3 mm/s – 7.5mm/s     |
| Identified Potentially Vulnerable Structures and Buildings with Low Vibration Threshold | 3mm/s   |                      |

- *Note 1: The relevant threshold value to be determined on a case by case basis. Where sufficient structural information is unavailable at the time of assessment, the lower value within the range will be used.*

Table 5 – Thresholds relating to the Transient and Continuous Vibrations in buildings and structures

### 7.3.4 Mitigation Measures to be put in place prior to works

For controlling vibration reference should be made to BS 5228:2009+A1:2014 which offers detailed guidance on the control of vibration from demolition and construction activities. In general BS5228:2009+A1:2014 advises the following:

- Use rubber linings in, for example, chutes and dumpers to reduce impact noise.
- Minimize drop height of materials.
- Regular and effective maintenance by trained personnel should be carried out to reduce vibration from plant and machinery.

- Hand demolition, cutting of the separation joints of the buildings in advance and small robotic breakers and 'munchers'

Level of protection and procedure put in place will be dictated by potential risk resulting from work to be carried out.

The proposed construction methodology for the structures directly adjacent to upstanding historic structures will be designed by the contractor to ensure that all protection measures are adhered to and that all new works are undertaken in such a way as to limit vibration.

All works within the sensitivity zones of the historic structures will be carried out using piling and excavation and assembly techniques to ensure vibration levels are kept below the threshold level.

### 7.3.5 Monitoring and Mitigation for Ground borne Vibrations during Construction Works

Detailed monitoring will be used to control the proposed works and to ensure compliance with the proposed control limit to protect the Historic Structures / Protected Structures / National Monument.

Vibrations movements will be actively measured during the works with a pre-determined plan of action ready to be put in place should actual measurements vary from the expected levels.

The works will have appropriate level of site management, on site monitoring and supervision. A site representative will be present during the works to ensure the levels are as expected and to supervise any measures should the levels be exceeded.

A real-time response remote monitoring system with warning system will be adopted to monitor vibration. This is to be continuously monitored by on site personnel during demolition; excavation; piling and general construction works. Review of the monitoring data will happen concurrently with the works to ensure that corrective action is undertaken if a limit is breached, or if the developing trend in measurements indicates a limit may be breached if works continue. This real time review and response of the monitoring data is critical to ensuring no limit is exceeded.

In the event that control limit is approached the contractor for the works will explore a revised approach for completion of the works.

Monitoring will include vibration monitoring carried out at the historic structures along with survey points installed on the walls of the historic structures to monitor any movement during the works.

Tell-tale crack monitors will also be installed on existing defects on the historic structures and or its boundary wall where appropriate.

In accordance with established good practice, baseline monitoring will be undertaken in advance of the proposed works in order to establish the existing environment around the historic structures and to verify the correct operation of the proposed instruments.

A series of trigger limits will be set for the works following what is commonly called a 'traffic light' system.

- For measurements below an 'amber limit' works can continue.
- For measurements between an 'amber/red limit' and below the 'red limit' operations will be suspended immediately. The construction methodology will be reviewed and adjusted as required to allow works to proceed on a manner that maintains the integrity of the historic structures.
- Works can continue between the amber and maximum red limit but only when methodologies have been revised to attempt to bring vibrations back below the amber level and also with a greater level of monitoring and control.

Should vibrations go above the red limit works will be suspended for a full review of the exceedance event(s); revision of works procedures and approval by the clients' representatives / OPW before operations can proceed again.

### 7.3.6 Limits for Ground Borne Vibrations

Vibration monitoring and controls are required to be installed prior to the works commencing and for the full duration of the works to ensure the proposed control limit is not exceeded thus avoiding adverse impacts on the historic structure.

A warning threshold shall be implemented as per the limits outlined in Tables 5 above.

Baseline vibration monitoring will be undertaken prior to commencement. The baseline readings should be referenced and incorporated into any Agreement with neighbouring properties and DCC on maximum vibration limits permissible when working nearby.

Toolbox talks should also be carried out with personnel in respect to managing vibration on site. Exposure limits as set out in Regulation 4 of BS 5228:2009+A1:2014 will be reviewed, risk assessments carried out, detecting signs of injury, safe working practices and suppression techniques will all be incorporated. Methods of construction should be adopted to omit and or control vibration at the source, utilize lower levels of vibration; use vibration pads and gloves where possible. Any activity which will generate vibration should as far as practicable be isolated from sensitive receptors.

## 7.4 Air & Dust Management

A dust management plan will be compiled by the Main Contractor for the development.

The following precautions to minimise nuisance to the public and neighbouring occupiers caused by dust and dirt will be carried out by the contractor.

- Vehicle and wheel washing facilities shall be provided at site exit where practicable. If necessary, vehicles are to be washed down before exiting the site.
- Netting is to be provided to enclose scaffolding to mitigate escape of air borne dust from the existing buildings.
- Shroud piling machinery as shown below when operating near to boundaries.
- Engines and exhaust systems should be maintained so that exhaust emissions do not breach stationary emission limits set for the vehicle / equipment type and mode of operation.
- Dust emission over the site boundary should be minimised using static sprinklers or other watering methods as necessary.
- No burning of materials to be permitted on site.
- Water sprays for dust suppression should be affixed to mechanical excavators/munchers involved in demolition works.
- Demolition waste should be removed from site as quickly as possible to minimise risk of dust generation and any fine material should be covered with a tarpaulin or similar material and tied down.
- Water sprays and cannons should be used where possible during cutting, with protective measures applied to retained finishes local to the cutting.
- Prior to commencement, the Main Contractor should identify the construction operations which are likely to generate dust and to draw up action plans to minimise emissions.
- In areas of poor natural ventilation, dust capture/extraction methods should be employed by the Main Contractor.
- The Main Contractor should allocate suitably qualified and experienced personnel to be responsible for ensuring the generation of dust is minimised and effectively controlled.
- The Main Contractor will be required to appoint a senior member of its site management team to act as the liaison with third parties in respect of complaints regarding dust and or site activities.
- Monitoring of dust deposition should be undertaken at nominated boundary locations to ensure that dust levels comply with the TA Lift limit value of 350mg/(m<sup>2</sup>/day) based on a 30-day average using Bergerhoff gauges (Limits to be agreed with local authority).



*Figure 45 – Typical Dust Mitigation Measures*

## 8. Construction and Demolition Waste Management

AWN Consulting Ltd. has prepared a Site-specific Construction & Demolition Waste Management Plan (C&D WMP) on behalf of Dublin Central GP Limited and is submitted as part of this planning application [document reference CB/20/11784WMR01].

The C&D WMP provides information necessary to ensure that the management of C&D waste at the site is undertaken in accordance with the current legal and industry standards including the Waste Management Acts 1996 - 2011 and associated Regulations, Protection of the Environment Act 2003 as amended, Litter Pollution Act 1997 as amended and the Eastern-Midlands Region Waste Management Plan 2015 – 2021.

In particular, the C&D WMP aims to ensure maximum recycling, reuse and recovery of waste with diversion from landfill, wherever possible. It also seeks to provide guidance on the appropriate collection and transport of waste from the site to prevent issues associated with litter or more serious environmental pollution (e.g. contamination of soil and/or water).

The C&D WMP includes information on the legal and policy framework for C&D waste management in Ireland, estimates of the type and quantity of waste to be generated by the proposed development and makes recommendations for management of different waste streams.

### 8.1 Non-Hazardous Construction Waste

There will be waste materials generated from the demolition and renovation of the existing buildings, hardstanding areas on site, as well as from the further excavation of the building foundations. The volume of waste generated from demolition will be more difficult to segregate than waste generated from the construction phase, as many of the building materials will be bonded together or integrated i.e. plasterboard on timber ceiling joists, steel embedded in concrete etc.

There will be soil, stones, clay and made ground excavated to facilitate construction of new foundations, underground services, and the installation of the proposed basements. The preliminary estimated 163,490m<sup>3</sup> of material will need to be excavated to do so. There is limited chance for reuse of material onsite and it is envisaged that all material, will need to be removed offsite due to the limited opportunities for reuse on site. This will be taken for appropriate offsite reuse, recovery, recycling and/or disposal.

During the construction phase there may be a surplus of building materials, such as timber off-cuts, broken concrete blocks, cladding, plastics, metals and tiles generated. There may also be excess concrete during construction which will need to be disposed of. Plastic and cardboard waste from packaging and supply of materials will also be generated. The contractor will be required to ensure that oversupply of materials is kept to a minimum and opportunities for reuse of suitable materials is maximised.

Waste will also be generated from construction workers e.g. organic/food waste, dry mixed recyclables (waste paper, newspaper, plastic bottles, packaging, aluminium cans, tins and Tetra Pak cartons), mixed non-recyclables and potentially sewage sludge from temporary welfare facilities provided on site during the construction phase. Waste printer/toner cartridges, waste electrical and electronic equipment (WEEE) and waste batteries may also be generated infrequently from site offices.

## 8.2 Potential Hazardous Wastes Arising

### 8.2.1 Contaminated Soil

In 2008 an initial joint geotechnical and environmental site investigation was undertaken (by O' Callaghan Moran & Associates) comprising the excavation of trial pits, the installation of boreholes in the subsoils and bedrock and the collection and testing of soil and groundwater samples. The intrusive investigations were confined to open areas in the middle of the site and around the site parameter. It is envisaged that further site investigations and environmental soil analysis will be undertaken post demolition and prior to any excavated material being removed from site.



Figure 46 – Site 2 areas of Potential Contaminated Material

Three (3) samples of the fill material from BH-7, 9 and 10 were analysed for Total Petroleum Hydrocarbons (TPH), BETX (benzene, toluene, ethylbenzene and xylene), PAH (polycyclic aromatic hydrocarbons) and metals (arsenic, barium, cadmium, chromium, copper, mercury, molybdenum, nickel, lead, tin, selenium and zinc).

Nineteen (19) samples, of the fill and natural ground from, BH-7, 9, 10, 12, 14, 15, RC-8 and W-2, were tested for the WAC, which included Total Organic Carbon (TOC), BETX, PCBs (polychlorinated biphenyls, 7 congeners), Mineral Oil (C10 to C40) and PAH sum of 17. They were also subjected to leach testing at a liquid to solid ratio of 10:1 and the leachate analysed for arsenic, barium, cadmium, chromium, copper, mercury, molybdenum, nickel, lead, tin, selenium, zinc, chloride, fluoride, sulphate, phenols, dissolved organic carbon and total dissolved solids.

If any potentially contaminated material is encountered, it will need to be segregated from clean/inert material, tested and classified as either non-hazardous or hazardous in accordance with the EPA publication entitled 'Waste Classification: List of Waste & Determining if Waste is Hazardous or Non-Hazardous' using the HazWasteOnline application (or similar approved classification method). The material will then need to be classified as clean, inert, non-hazardous or hazardous in accordance with the EC Council Decision 2003/33/EC, which establishes the criteria for the acceptance of waste at landfills.

In the event that Asbestos containing materials (ACMs) are found, the removal will only be carried out by a suitably permitted waste contractor, in accordance with S.I. No. 386 of 2006 Safety, Health and Welfare



at Work (Exposure to Asbestos) Regulations 2006-2010. All asbestos will be taken to a suitably licensed or permitted facility.

In the event that hazardous soil, or historically deposited waste is encountered during the construction phase, the contractor will notify DCC and provide a Hazardous/Contaminated Soil Management Plan, to include estimated tonnages, description of location, any relevant mitigation, destination for disposal/treatment, in addition to information on the authorised waste collector(s).

### 8.2.2 Fuel/Oils

Fuels and oils are classed as hazardous materials; any on-site storage of fuel/oil, and all storage tanks and all draw-off points will be bunded and located in a dedicated, secure area of the site. Provided that these requirements are adhered to and the site crew are trained in the appropriate refuelling techniques, it is not expected that there will be any fuel/oil waste generated at the site.

### 8.2.3 Invasive Plant Species

An ecological site survey was undertaken by Scott Cawley Ecology in June 2020. This included a site walkover survey of the entire site, and around part of the outside perimeter to search for any schedule 3 invasive species. Japanese Knotweed *Fallopia japonica*, which is listed on the Third Schedule of the Birds and Habitats Regulations, was not recorded on the site.

Japanese Knotweed (*Fallopia japonica*) is an alien invasive species listed under schedule 3 of Regulations SI No. 355/2015. SCE's report concludes that it is not present on this site and there was no indication that it is growing in the immediate vicinity.

### 8.2.4 Asbestos

Multiple asbestos refurbishment/demolition survey were undertaken by About Safety Ltd in September and October 2020. The scope of the survey's were confined to all accessible areas of the existing buildings which are due for demolition and/or refurbishment in the future.

Asbestos Containing Materials (ACM) were detected in several locations within some of the buildings including but not limited to floor tiling, roof slates, roof felt, rope seals, bitumen and woven rope.

Removal of asbestos or ACMs will be carried out by a suitably qualified contractor and ACM's will only be removed from site by a suitably permitted/licenced waste contractor. in accordance with S.I. No. 386 of 2006 Safety, Health and Welfare at Work (Exposure to Asbestos) Regulations 2006-2010. All material will be taken to a suitably licensed or permitted facility.

### 8.2.5 Other known Hazardous Substances

Paints, glues, adhesives and other known hazardous substances will be stored in designated areas. They will generally be present in small volumes only and associated waste volumes generated will be kept to a minimum. Wastes will be stored in appropriate receptacles pending collection by an authorised waste contractor.

In addition, WEEE (containing hazardous components), printer toner/cartridges, batteries (Lead, Ni-Cd or Mercury) and/or fluorescent tubes and other mercury containing waste may be generated from during C&D activities or temporary site offices. These wastes, if generated, will be stored in appropriate receptacles in designated areas of the site pending collection by an authorised waste contractor.

### 8.3 Main Construction and Demolition Waste Categories

AWN Consulting Ltd. has prepared Site-specific Construction & Demolition Waste Management Plan submitted as part of this planning application [document reference CB/20/11784WMR01] and is summarized below.

The main non-hazardous and hazardous waste streams that could be generated by the demolition and construction activities at a typical site are shown in. The List of Waste (LoW) code (as effected from 1 June 2015) (also referred to as the European Waste Code or EWC) for each waste stream is also shown.

| Waste Material   | LoW/EWC Code        |
|--|---------------------|
| Concrete, bricks, tiles, ceramics                                    | 17 01 01-03 & 07    |
| Wood, glass and plastic  | 17 02 01-03         |
| Treated wood, glass, plastic, containing hazardous substances        | 17-02-04*           |
| Bituminous mixtures, coal tar and tarred products                    | 17 03 01*, 02 & 03* |
| Metals (including their alloys) and cable                            | 17 04 01-11         |
| Soil and stones  | 17 05 03* & 04      |
| Gypsum-based construction material                                   | 17 08 01* & 02      |
| Paper and cardboard  | 20 01 01            |
| Mixed C&D waste  | 17 09 04            |
| Green waste  | 20 02 01            |
| Electrical and electronic components                                 | 20 01 35 & 36       |
| Batteries and accumulators   | 20 01 33 & 34       |
| Liquid fuels   | 13 07 01-10         |
| Chemicals (solvents, pesticides, paints, adhesives, detergents etc.) | 20 01 13, 19, 27-30 |
| Insulation materials   | 17 06 04            |
| Organic (food) waste   | 20 01 08            |
| Mixed Municipal Waste  | 20 03 01            |

\* individual waste type may contain hazardous substances

Table 1. Typical waste types generated and LoW codes (individual waste types may contain hazardous substances)

## 8.4 Demolition Waste Generation

The demolition stage will involve the demolition of multiple brick buildings onsite. The demolition areas are identified in the planning drawings provided with this application. The anticipated demolition waste and rates of reuse, recycling/recovery and disposal is shown in Table 2 and 3.

| Waste Type                        | Tonnes         | Reuse |               | Recycle/Recovery |               | Disposal |               |
|-----------------------------------|----------------|-------|---------------|------------------|---------------|----------|---------------|
|                                   |                | %     | Tonnes        | %                | Tonnes        | %        | Tonnes        |
| Glass                             | 1216.2         | 0     | 0.0           | 85               | 1033.7        | 15       | 182.4         |
| Concrete, Bricks, Tiles, Ceramics | 6891.5         | 30    | 2067.5        | 65               | 4479.5        | 5        | 344.6         |
| Plasterboard                      | 540.5          | 30    | 162.2         | 60               | 324.3         | 10       | 54.1          |
| Asphalts                          | 135.1          | 0     | 0.0           | 25               | 33.8          | 75       | 101.3         |
| Metals                            | 2026.9         | 5     | 101.3         | 80               | 1621.5        | 15       | 304.0         |
| Slate                             | 1081.0         | 0     | 0.0           | 85               | 918.9         | 15       | 162.2         |
| Timber                            | 1621.5         | 10    | 162.2         | 60               | 972.9         | 30       | 486.5         |
| Asbestos                          | 2.0            | 0     | 0.0           | 0                | 0.0           | 100      | 2.0           |
| <b>Total</b>                      | <b>13514.7</b> |       | <b>2493.1</b> |                  | <b>9384.6</b> |          | <b>1637.0</b> |

Table 2. Estimated off-site reuse, recycle and disposal rates for demolition waste from Site 2

| Waste Type   | Tonnes        | Reuse |              | Recycle/Recovery |               | Disposal |              |
|--------------|---------------|-------|--------------|------------------|---------------|----------|--------------|
|              |               | %     | Tonnes       | %                | Tonnes        | %        | Tonnes       |
| Mixed C&D    | 871.1         | 10    | 87.1         | 80               | 696.9         | 10       | 87.1         |
| Timber       | 739.1         | 40    | 295.6        | 55               | 406.5         | 5        | 37.0         |
| Plasterboard | 264.0         | 30    | 79.2         | 60               | 158.4         | 10       | 26.4         |
| Metals       | 211.2         | 5     | 10.6         | 90               | 190.1         | 5        | 10.6         |
| Concrete     | 158.4         | 30    | 47.5         | 65               | 102.9         | 5        | 7.9          |
| Other        | 396.0         | 20    | 79.2         | 60               | 237.6         | 20       | 79.2         |
| <b>Total</b> | <b>2639.7</b> |       | <b>599.2</b> |                  | <b>1792.3</b> |          | <b>248.1</b> |

Table 3. Estimated off-site reuse, recycle and disposal rates for construction waste from Site 2

## **8.5 Appointment of C&D Waste Manager**

The Main Contractor/Contractors will appoint a C&D Waste Manager. The C&D Waste Manager will have overall responsibility for the implementation of the project Waste Management Plan (WMP) during the construction phase.

Copies of the Waste Management Plan will be made available to all relevant personnel on site. All site personnel and sub-contractors will be instructed regarding the objectives of the Waste Management Plan and informed of the responsibilities which fall upon them as a consequence of its provisions. Where source segregation, selective demolition and material reuse techniques apply, each member of staff will be given instructions on how to comply with the Waste Management Plan. Posters will be designed to reinforce the key messages within the Waste Management Plan and will be displayed prominently for the benefit of site staff.

## **9. Archaeology**

Archaeological monitoring will take place where any preparatory ground reduction works are required including site investigation works and opening up works at basement or ground levels. Post-demolition archaeological investigation will be carried out in areas across the site without basements. This is required to establish the nature of below ground structures, foundation remnants and features of archaeological and historical importance and to establish the presence or otherwise of archaeological remains. Further resolution may involve the recording of historic features and full archaeological excavation (i.e., preservation of the archaeology in record form, of all archaeological soils or features encountered). The resolution will occur during this post demolition phase in the area of the find spot in advance of the main construction phase.

## **10. Building Control Amendment Regulations**

### **10.1 Quality Assurance during Construction and BC(A)R Compliance**

The Main Contractor/Contractors will need to demonstrate how they will be providing quality in construction. They shall comply fully with all requirements of the Amended Building Control regulations to the satisfaction of the Ancillary and Assigned certifiers.

The Main Contractor/Contractors will be responsible for the preparation of benchmark samples of each new element of the works to the satisfaction of the Assigned and Ancillary Certifiers under the Building Control regulations (BCAR). Each benchmark sample will be considered a 'hold point' under the Preliminary Inspection Plan (PIP) and will be required to be offered up to the Certifiers involved ahead of the works starting - with a minimum of two days' notice (in writing).

The Main Contractor/Contractors will be required to keep pre- and post-pour check sheets for submission to the assigned and ancillary certifiers where required.

Written acceptance will be required from the Certifiers after inspection of the benchmark samples before the rest of the works proceed.

Where 'specialist' suppliers are noted by the design team to have design responsibility, they will be required to provide Certificates of Design (Sd), Certificates of Inspection (Si) and Certificates of Completion (Sc). Ahead of appointment of the 'specialist' suppliers / designers - evidence of competency and Professional Indemnity insurance cover will be required for the approval of the Contract Administrator and Waterman Moylan.

This is to be confirmed by the Main Contractor/Contractors once appointed and will include a quality check regime.

## **11. Liaison with Third Parties**

It is imperative that the Main Contractor/Contractors engages in discussions with local residents, businesses and the general public well in advance of work commencing on site. Formal communication should be provided to immediate neighbours regarding activities or possible disruptions.

The appointed contractor will be required to adopt the practices covered under the 'Considerate Constructors Scheme' for establishing a good neighbour strategy and maintaining good relationships with neighbouring communities. The ideas described within this scheme will be implemented on site where applicable to minimize negative impact on local community and the environment.

Handling of any complaints must be logged and actioned quickly by the Main Contractor/Contractors.

# APPENDIX A

## Site 2 – Site Setup

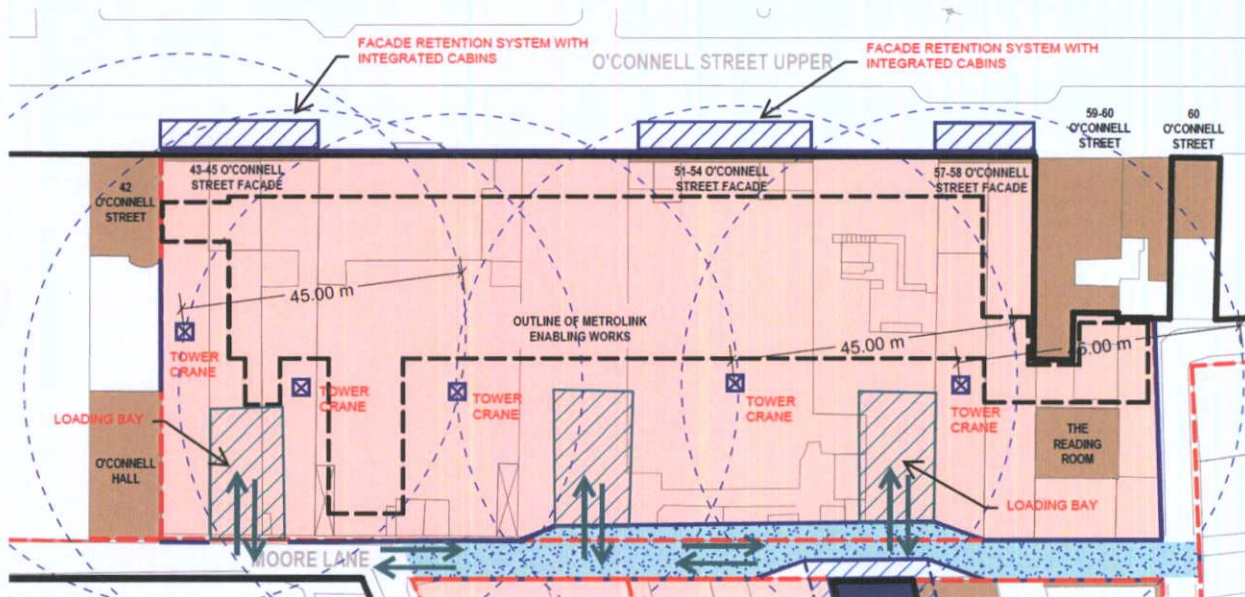



**APPENDIX B**

**Site 2 – Construction Sequencing**

DCC PLAN NO 5126/22  
RECEIVED: 26/10/2022

# TIMESLICE IMAGES FOLLOW

- Assumes Planning Approval Granted in September 2023
- A protected zone will be established around the National Monument and a temporary haul road will be installed.
- The Construction Management Plan provides further detail as to the approach to be taken and therefore reference should be made to that document when considering this.

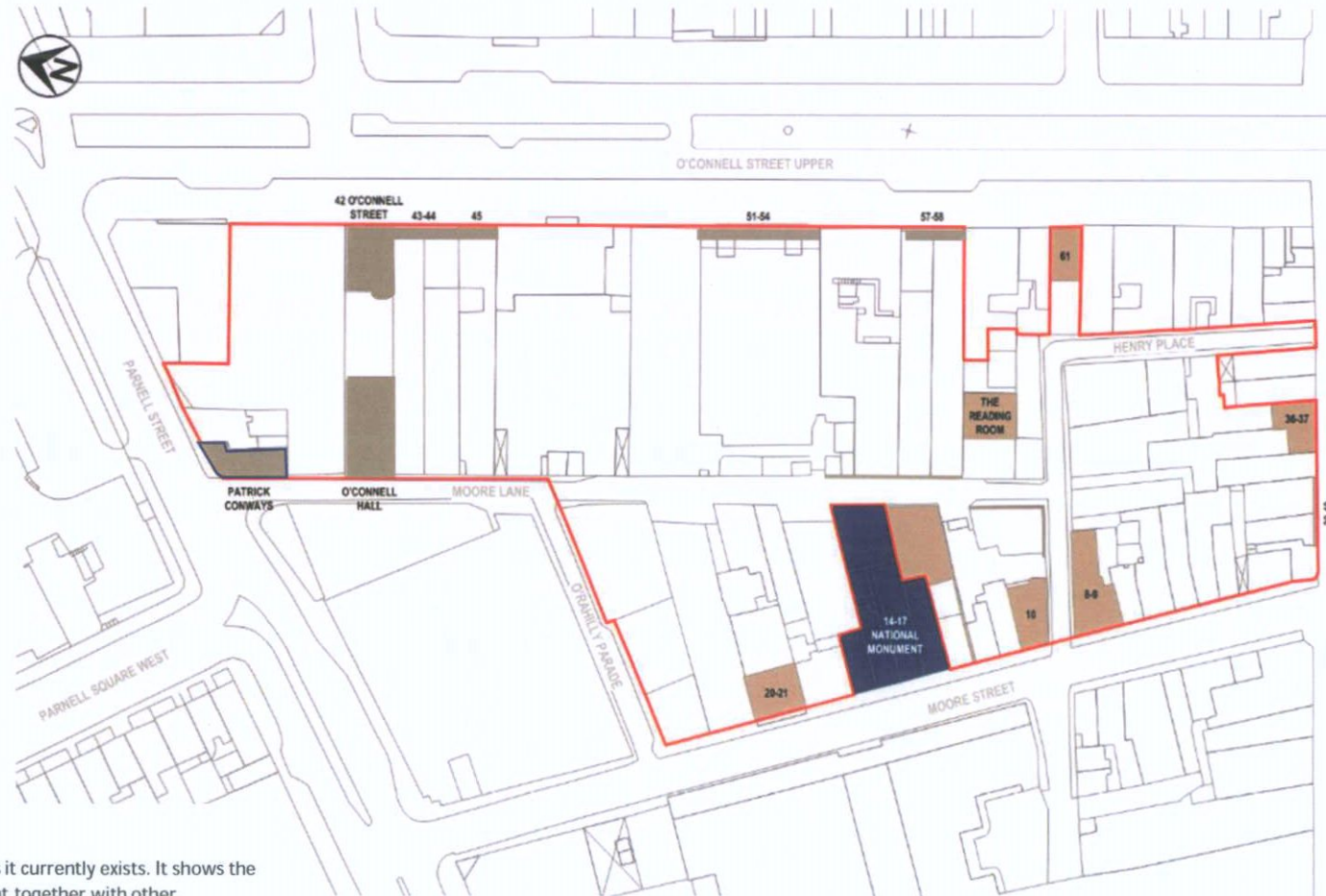

**Principal activities taking place:**

This image demonstrates the site as it currently exists. It shows the proximity of the National Monument together with other Protected Structures and Non-Protected structures of historical significance to be retained.

| 2022 |    |    |    | 2023 |    |    |    | 2024 |    |    |    | 2025 |    |    |    | 2026 |    |    |    | 2027 |    |    |    | 2028 |    |    |    | 2029 |    |    |    | 2030 |    |    |    | 2031 |    |    |    | 2032 |    |    |    | 2033 |  |  |  |  |  |  |  |
|------|----|----|----|------|----|----|----|------|----|----|----|------|----|----|----|------|----|----|----|------|----|----|----|------|----|----|----|------|----|----|----|------|----|----|----|------|----|----|----|------|----|----|----|------|--|--|--|--|--|--|--|
| Q1   | Q2 | Q3 | Q4 | Q1   | Q2 | Q3 | Q4 | Q1   | Q2 | Q3 | Q4 | Q1   | Q2 | Q3 | Q4 | Q1   | Q2 | Q3 | Q4 | Q1   | Q2 | Q3 | Q4 | Q1   | Q2 | Q3 | Q4 | Q1   | Q2 | Q3 | Q4 | Q1   | Q2 | Q3 | Q4 | Q1   | Q2 | Q3 | Q4 | Q1   | Q2 | Q3 | Q4 |      |  |  |  |  |  |  |  |
|      |    |    |    |      |    |    |    |      |    |    |    |      |    |    |    |      |    |    |    |      |    |    |    |      |    |    |    |      |    |    |    |      |    |    |    |      |    |    |    |      |    |    |    |      |  |  |  |  |  |  |  |

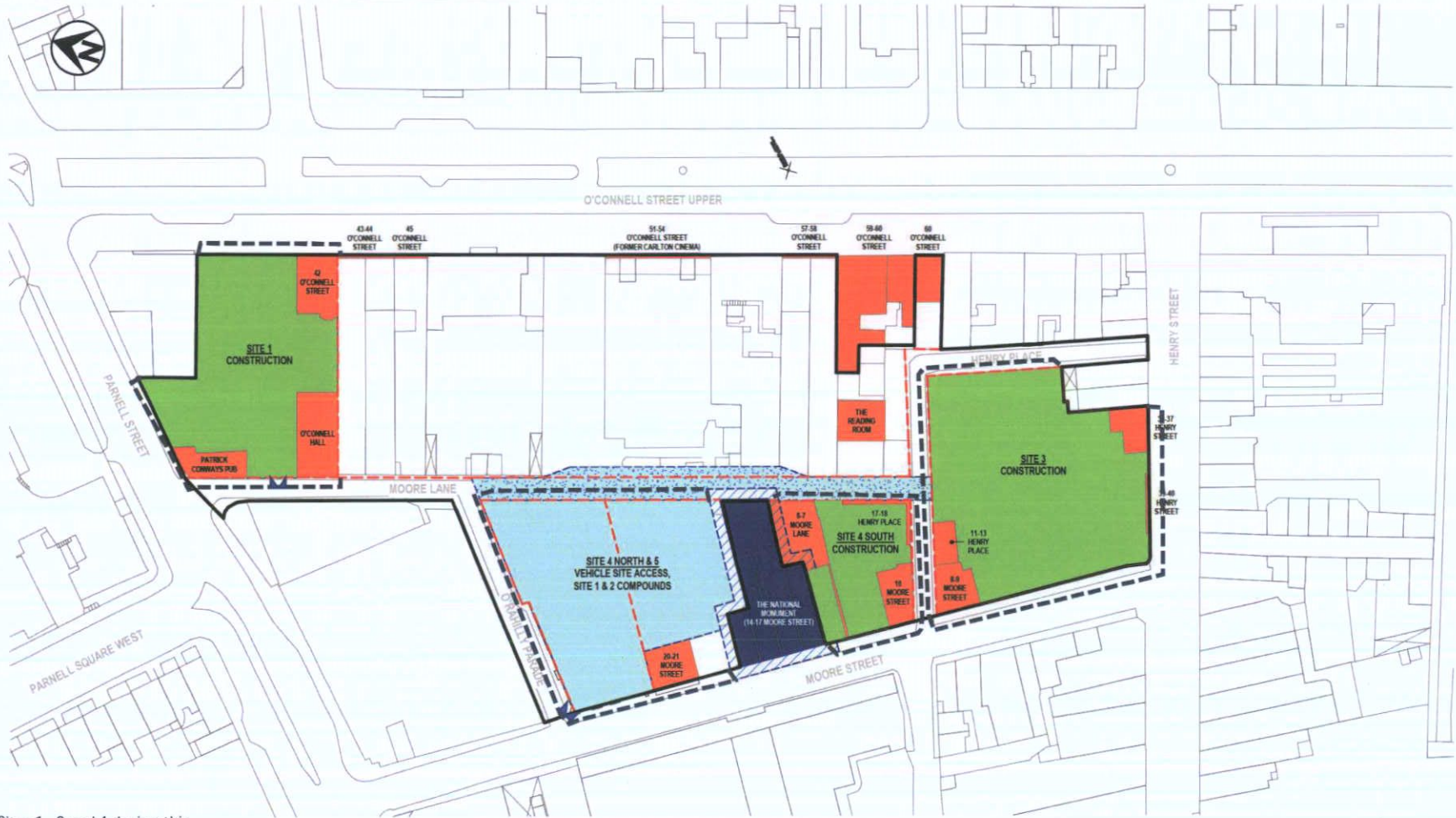

PRELIMINARY PROJECT PROGRAMME – INDICATIVE ONLY

**Principal activities taking place:**

Construction work commences on Sites 1, 3 and 4 during this period, and Site 5 is hoarded off to provide the necessary vehicle unloading area to service all of the construction sites.

| 2022 |    |    |    | 2023 |    |    |    | 2024 |    |    |    | 2025 |    |    |    | 2026 |    |    |    | 2027 |    |    |    | 2028 |    |    |    | 2029 |    |    |    | 2030 |    |    |    | 2031 |    |    |    | 2032 |    |    |    | 2033 |  |  |  |  |  |  |  |
|------|----|----|----|------|----|----|----|------|----|----|----|------|----|----|----|------|----|----|----|------|----|----|----|------|----|----|----|------|----|----|----|------|----|----|----|------|----|----|----|------|----|----|----|------|--|--|--|--|--|--|--|
| Q1   | Q2 | Q3 | Q4 | Q1   | Q2 | Q3 | Q4 | Q1   | Q2 | Q3 | Q4 | Q1   | Q2 | Q3 | Q4 | Q1   | Q2 | Q3 | Q4 | Q1   | Q2 | Q3 | Q4 | Q1   | Q2 | Q3 | Q4 | Q1   | Q2 | Q3 | Q4 | Q1   | Q2 | Q3 | Q4 | Q1   | Q2 | Q3 | Q4 | Q1   | Q2 | Q3 | Q4 |      |  |  |  |  |  |  |  |
|      |    |    |    |      |    |    |    |      |    |    |    |      |    |    |    |      |    |    |    |      |    |    |    |      |    |    |    |      |    |    |    |      |    |    |    |      |    |    |    |      |    |    |    |      |  |  |  |  |  |  |  |



PRELIMINARY PROJECT PROGRAMME - INDICATIVE ONLY

**Principal activities taking place:**

At the start of this period the demolition and construction work for the MEW commences.

Construction work continues on Sites 1, 3 and 4 during this period, and Site 5 remains hoarded off to provide the necessary vehicle unloading area to service all of the construction sites.

| 2022 |    |    |    | 2023 |    |    |    | 2024 |    |    |    | 2025 |    |    |    | 2026 |    |    |    | 2027 |    |    |    | 2028 |    |    |    | 2029 |    |    |    | 2030 |    |    |    | 2031 |    |    |    | 2032 |    |    |    | 2033 |  |  |  |  |  |  |  |  |  |  |  |
|------|----|----|----|------|----|----|----|------|----|----|----|------|----|----|----|------|----|----|----|------|----|----|----|------|----|----|----|------|----|----|----|------|----|----|----|------|----|----|----|------|----|----|----|------|--|--|--|--|--|--|--|--|--|--|--|
| Q1   | Q2 | Q3 | Q4 | Q1   | Q2 | Q3 | Q4 | Q1   | Q2 | Q3 | Q4 | Q1   | Q2 | Q3 | Q4 | Q1   | Q2 | Q3 | Q4 | Q1   | Q2 | Q3 | Q4 | Q1   | Q2 | Q3 | Q4 | Q1   | Q2 | Q3 | Q4 | Q1   | Q2 | Q3 | Q4 | Q1   | Q2 | Q3 | Q4 | Q1   | Q2 | Q3 | Q4 |      |  |  |  |  |  |  |  |  |  |  |  |
|      |    |    |    |      |    |    |    |      |    |    |    |      |    |    |    |      |    |    |    |      |    |    |    |      |    |    |    |      |    |    |    |      |    |    |    |      |    |    |    |      |    |    |    |      |  |  |  |  |  |  |  |  |  |  |  |



PRELIMINARY PROJECT PROGRAMME – INDICATIVE ONLY

**Principal activities taking place:**

Site 1 completes, the construction of the MEW continues, Site 3 enters its fitting out phase, and Site 4 remains under construction.

Site 5 remains hoarded off to provide the necessary vehicle unloading area to service all of the construction sites.

| 2022 |    |    |    | 2023 |    |    |    | 2024 |    |    |    | 2025 |    |    |    | 2026 |    |    |    | 2027 |    |    |    | 2028 |    |    |    | 2029 |    |    |    | 2030 |    |    |    | 2031 |    |    |    | 2032 |    |    |    | 2033 |  |  |  |  |  |  |  |
|------|----|----|----|------|----|----|----|------|----|----|----|------|----|----|----|------|----|----|----|------|----|----|----|------|----|----|----|------|----|----|----|------|----|----|----|------|----|----|----|------|----|----|----|------|--|--|--|--|--|--|--|
| Q1   | Q2 | Q3 | Q4 | Q1   | Q2 | Q3 | Q4 | Q1   | Q2 | Q3 | Q4 | Q1   | Q2 | Q3 | Q4 | Q1   | Q2 | Q3 | Q4 | Q1   | Q2 | Q3 | Q4 | Q1   | Q2 | Q3 | Q4 | Q1   | Q2 | Q3 | Q4 | Q1   | Q2 | Q3 | Q4 | Q1   | Q2 | Q3 | Q4 | Q1   | Q2 | Q3 | Q4 |      |  |  |  |  |  |  |  |
|      |    |    |    |      |    |    |    |      |    |    |    |      |    |    |    |      |    |    |    |      |    |    |    |      |    |    |    |      |    |    |    |      |    |    |    |      |    |    |    |      |    |    |    |      |  |  |  |  |  |  |  |



PRELIMINARY PROJECT PROGRAMME – INDICATIVE ONLY

**Principal activities taking place:**

Site 3 now completes together with the public realm around it. Henry Place is opened up to public use together with the central passageway through Site 3.

The construction of the MEW continues, and Site 4 enters its fitting out phase.

Site 5 remains hoarded off to provide the necessary vehicle unloading area to service all of the construction sites.

| 2022 |    |    |    | 2023 |    |    |    | 2024 |    |    |    | 2025 |    |    |    | 2026 |    |    |    | 2027 |    |    |    | 2028 |    |    |    | 2029 |    |    |    | 2030 |    |    |    | 2031 |    |    |    | 2032 |    |    |    | 2033 |  |  |  |  |  |  |  |
|------|----|----|----|------|----|----|----|------|----|----|----|------|----|----|----|------|----|----|----|------|----|----|----|------|----|----|----|------|----|----|----|------|----|----|----|------|----|----|----|------|----|----|----|------|--|--|--|--|--|--|--|
| Q1   | Q2 | Q3 | Q4 | Q1   | Q2 | Q3 | Q4 | Q1   | Q2 | Q3 | Q4 | Q1   | Q2 | Q3 | Q4 | Q1   | Q2 | Q3 | Q4 | Q1   | Q2 | Q3 | Q4 | Q1   | Q2 | Q3 | Q4 | Q1   | Q2 | Q3 | Q4 | Q1   | Q2 | Q3 | Q4 | Q1   | Q2 | Q3 | Q4 | Q1   | Q2 | Q3 | Q4 |      |  |  |  |  |  |  |  |
|      |    |    |    |      |    |    |    |      |    |    |    |      |    |    |    |      |    |    |    |      |    |    |    |      |    |    |    |      |    |    |    |      |    |    |    |      |    |    |    |      |    |    |    |      |  |  |  |  |  |  |  |

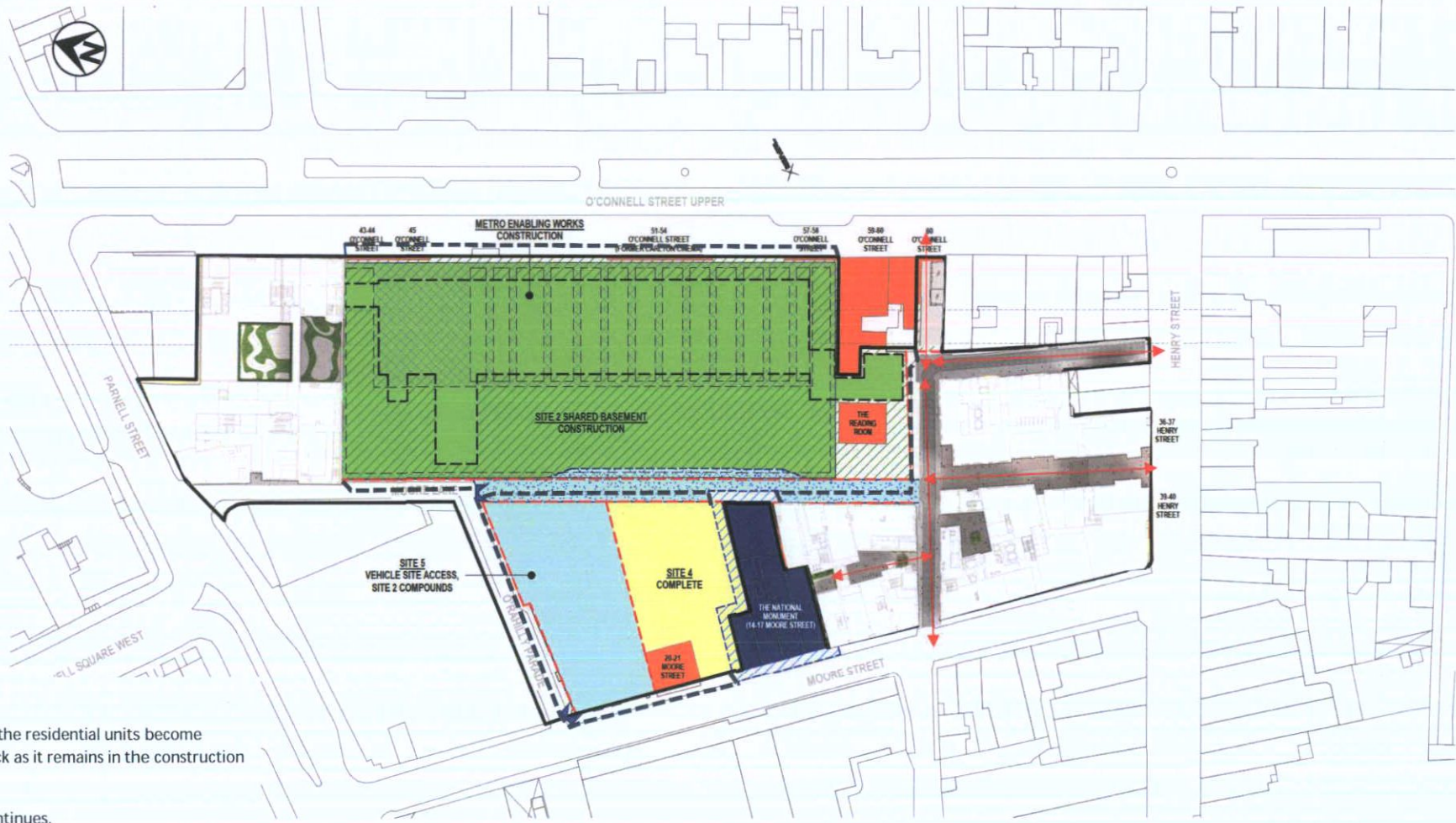

Principal activities taking place:

Site 4 South now completes and the residential units become occupied. Site 4 North is held back as it remains in the construction zone without safe public access.

The construction of the MEW continues.

Site 5 remains hoarded off to provide the necessary vehicle unloading area to service all of the construction sites.

PRELIMINARY PROJECT PROGRAMME – INDICATIVE ONLY



| 2022 |    |    |    | 2023 |    |    |    | 2024 |    |    |    | 2025 |    |    |    | 2026 |    |    |    | 2027 |    |    |    | 2028 |    |    |    | 2029 |    |    |    | 2030 |    |    |    | 2031 |    |    |    | 2032 |    |    |    | 2033 |  |  |  |  |  |  |  |
|------|----|----|----|------|----|----|----|------|----|----|----|------|----|----|----|------|----|----|----|------|----|----|----|------|----|----|----|------|----|----|----|------|----|----|----|------|----|----|----|------|----|----|----|------|--|--|--|--|--|--|--|
| Q1   | Q2 | Q3 | Q4 | Q1   | Q2 | Q3 | Q4 | Q1   | Q2 | Q3 | Q4 | Q1   | Q2 | Q3 | Q4 | Q1   | Q2 | Q3 | Q4 | Q1   | Q2 | Q3 | Q4 | Q1   | Q2 | Q3 | Q4 | Q1   | Q2 | Q3 | Q4 | Q1   | Q2 | Q3 | Q4 | Q1   | Q2 | Q3 | Q4 | Q1   | Q2 | Q3 | Q4 |      |  |  |  |  |  |  |  |
|      |    |    |    |      |    |    |    |      |    |    |    |      |    |    |    |      |    |    |    |      |    |    |    |      |    |    |    |      |    |    |    |      |    |    |    |      |    |    |    |      |    |    |    |      |  |  |  |  |  |  |  |

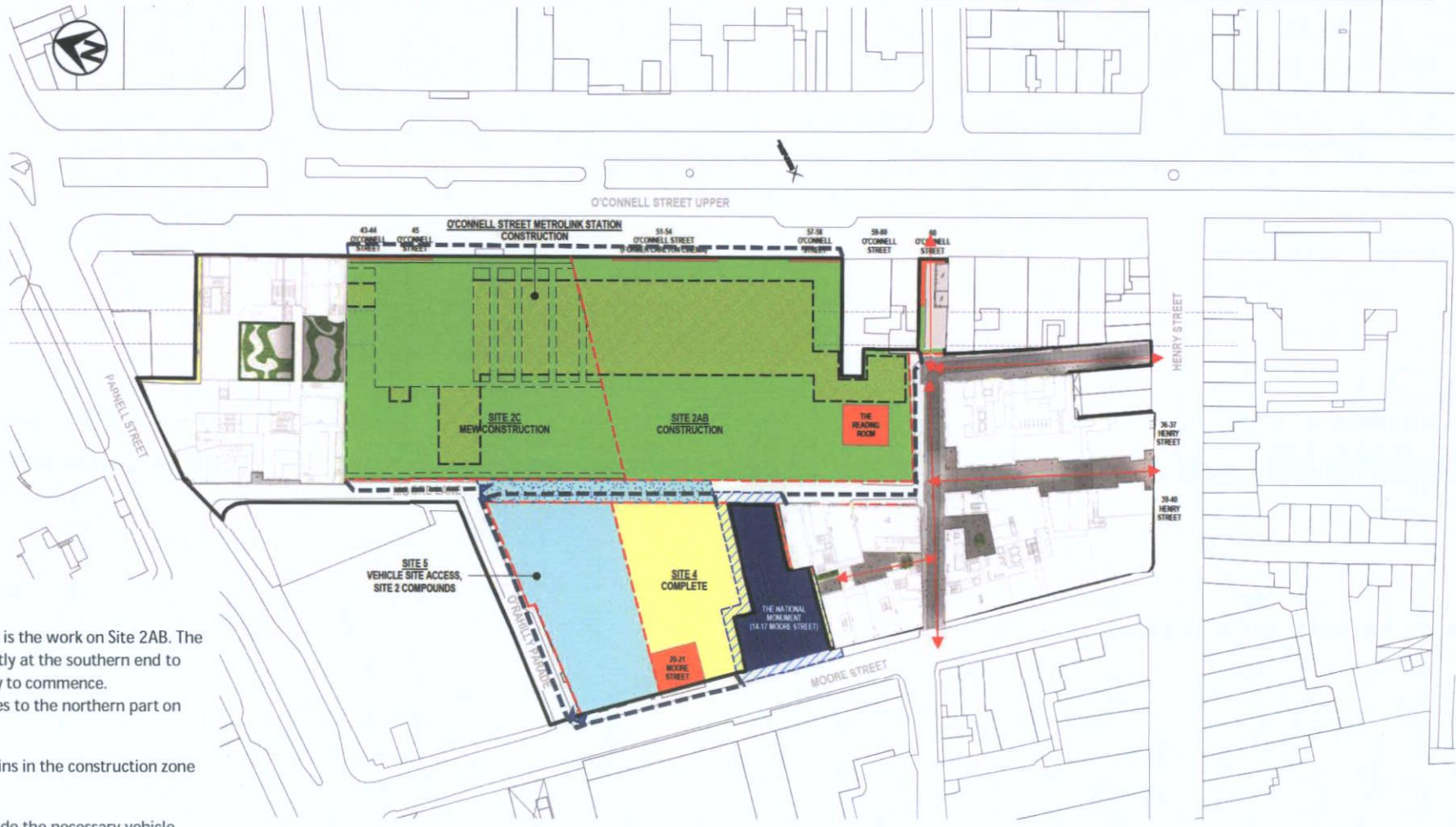

PRELIMINARY PROJECT PROGRAMME - INDICATIVE ONLY

Principal activities taking place:

The principal change on this image is the work on Site 2AB. The MEW are now completed sufficiently at the southern end to allow Site 2AB construction activity to commence. Construction on the MEW continues to the northern part on Site 2C.

Site 4 North is held back as it remains in the construction zone without safe public access.

Site 5 remains hoarded off to provide the necessary vehicle unloading area to service all of the construction sites.

| 2022 |    |    |    | 2023 |    |    |    | 2024 |    |    |    | 2025 |    |    |    | 2026 |    |    |    | 2027 |    |    |    | 2028 |    |    |    | 2029 |    |    |    | 2030 |    |    |    | 2031 |    |    |    | 2032 |    |    |    | 2033 |  |  |  |  |  |  |  |
|------|----|----|----|------|----|----|----|------|----|----|----|------|----|----|----|------|----|----|----|------|----|----|----|------|----|----|----|------|----|----|----|------|----|----|----|------|----|----|----|------|----|----|----|------|--|--|--|--|--|--|--|
| Q1   | Q2 | Q3 | Q4 | Q1   | Q2 | Q3 | Q4 | Q1   | Q2 | Q3 | Q4 | Q1   | Q2 | Q3 | Q4 | Q1   | Q2 | Q3 | Q4 | Q1   | Q2 | Q3 | Q4 | Q1   | Q2 | Q3 | Q4 | Q1   | Q2 | Q3 | Q4 | Q1   | Q2 | Q3 | Q4 | Q1   | Q2 | Q3 | Q4 | Q1   | Q2 | Q3 | Q4 |      |  |  |  |  |  |  |  |
|      |    |    |    |      |    |    |    |      |    |    |    |      |    |    |    |      |    |    |    |      |    |    |    |      |    |    |    |      |    |    |    |      |    |    |    |      |    |    |    |      |    |    |    |      |  |  |  |  |  |  |  |

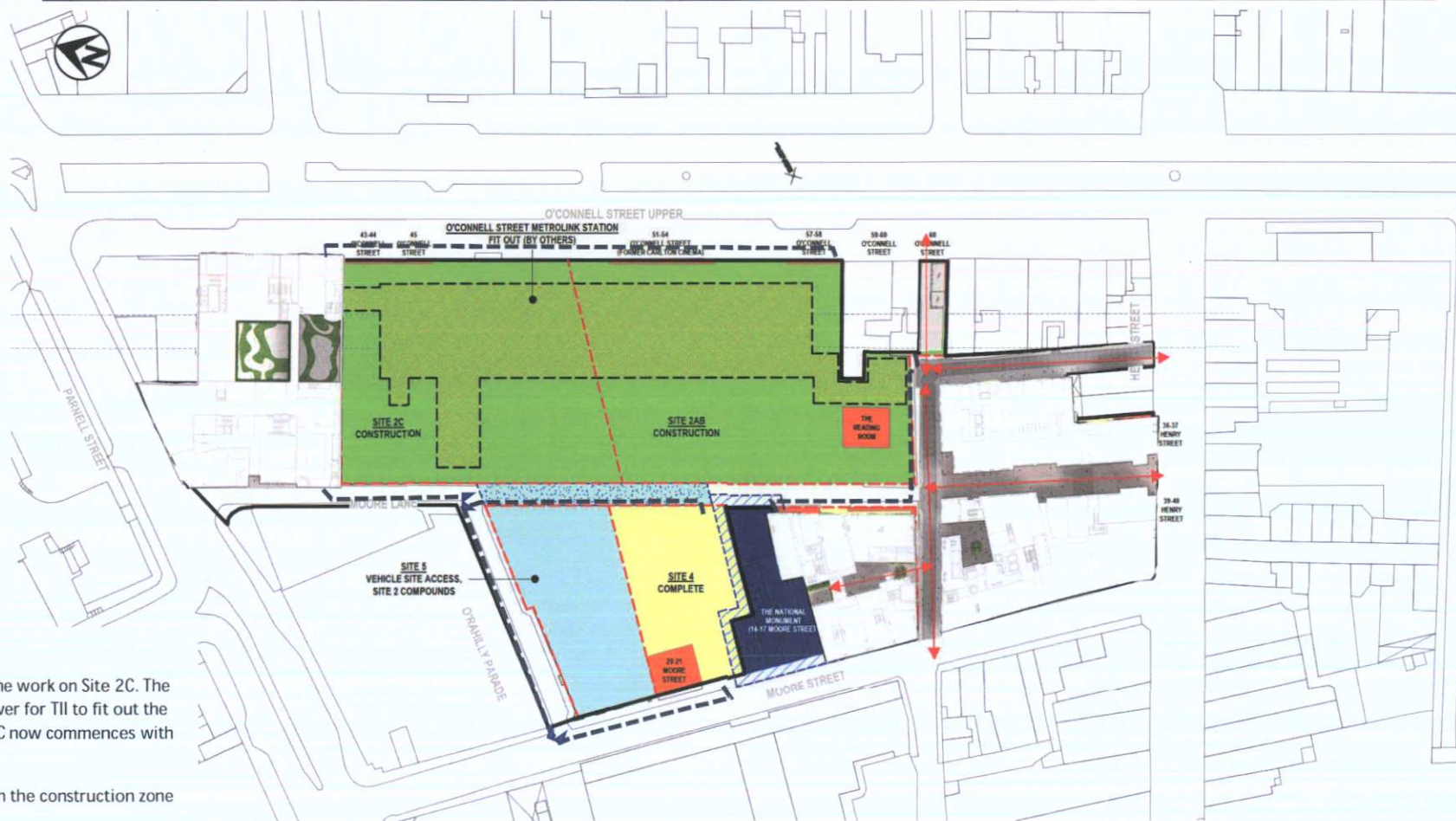

PRELIMINARY PROJECT PROGRAMME – INDICATIVE ONLY

**Principal activities taking place:**

The principal change on this image is the work on Site 2C. The MEW are now complete and handed over for TII to fit out the station, connect the tunnels etc. Site 2C now commences with its construction activity.

Site 4 North is held back as it remains in the construction zone without safe public access.

Site 5 remains hoarded off to provide the necessary vehicle unloading area to service all of the construction sites.

| 2022 |    |    |    | 2023 |    |    |    | 2024 |    |    |    | 2025 |    |    |    | 2026 |    |    |    | 2027 |    |    |    | 2028 |    |    |    | 2029 |    |    |    | 2030 |    |    |    | 2031 |    |    |    | 2032 |    |    |    | 2033 |  |  |  |  |  |  |  |
|------|----|----|----|------|----|----|----|------|----|----|----|------|----|----|----|------|----|----|----|------|----|----|----|------|----|----|----|------|----|----|----|------|----|----|----|------|----|----|----|------|----|----|----|------|--|--|--|--|--|--|--|
| Q1   | Q2 | Q3 | Q4 | Q1   | Q2 | Q3 | Q4 | Q1   | Q2 | Q3 | Q4 | Q1   | Q2 | Q3 | Q4 | Q1   | Q2 | Q3 | Q4 | Q1   | Q2 | Q3 | Q4 | Q1   | Q2 | Q3 | Q4 | Q1   | Q2 | Q3 | Q4 | Q1   | Q2 | Q3 | Q4 | Q1   | Q2 | Q3 | Q4 | Q1   | Q2 | Q3 | Q4 |      |  |  |  |  |  |  |  |
|      |    |    |    |      |    |    |    |      |    |    |    |      |    |    |    |      |    |    |    |      |    |    |    |      |    |    |    |      |    |    |    |      |    |    |    |      |    |    |    |      |    |    |    |      |  |  |  |  |  |  |  |



PRELIMINARY PROJECT PROGRAMME – INDICATIVE ONLY

**Principal activities taking place:**

The principal change on this image is the work on Site 2A, in that fitting out works now commence whilst construction on Site 2C continues. The Station fit out continues.

Site 4 North is held back as it remains in the construction zone without safe public access.

Site 5 remains hoarded off to provide the necessary vehicle unloading area to service all of the construction sites.

| 2022 |    |    |    | 2023 |    |    |    | 2024 |    |    |    | 2025 |    |    |    | 2026 |    |    |    | 2027 |    |    |    | 2028 |    |    |    | 2029 |    |    |    | 2030 |    |    |    | 2031 |    |    |    | 2032 |    |    |    | 2033 |  |  |  |  |  |  |  |
|------|----|----|----|------|----|----|----|------|----|----|----|------|----|----|----|------|----|----|----|------|----|----|----|------|----|----|----|------|----|----|----|------|----|----|----|------|----|----|----|------|----|----|----|------|--|--|--|--|--|--|--|
| Q1   | Q2 | Q3 | Q4 | Q1   | Q2 | Q3 | Q4 | Q1   | Q2 | Q3 | Q4 | Q1   | Q2 | Q3 | Q4 | Q1   | Q2 | Q3 | Q4 | Q1   | Q2 | Q3 | Q4 | Q1   | Q2 | Q3 | Q4 | Q1   | Q2 | Q3 | Q4 | Q1   | Q2 | Q3 | Q4 | Q1   | Q2 | Q3 | Q4 | Q1   | Q2 | Q3 | Q4 |      |  |  |  |  |  |  |  |
|      |    |    |    |      |    |    |    |      |    |    |    |      |    |    |    |      |    |    |    |      |    |    |    |      |    |    |    |      |    |    |    |      |    |    |    |      |    |    |    |      |    |    |    |      |  |  |  |  |  |  |  |

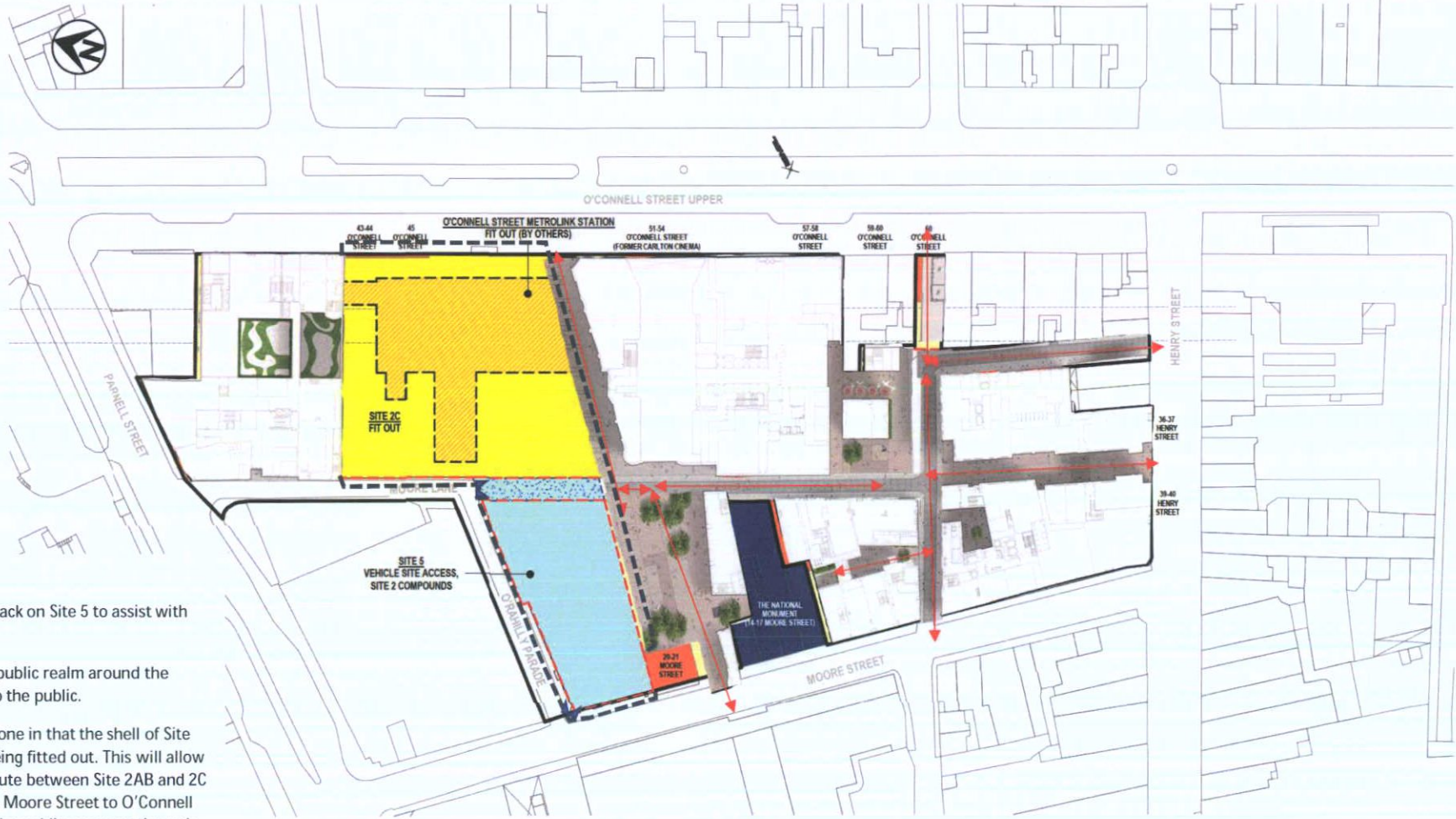

PRELIMINARY PROJECT PROGRAMME – INDICATIVE ONLY

**Principal activities taking place:**

This image shows the works held back on Site 5 to assist with the Station fit out as necessary.

Site 2AB will be complete and the public realm around the Reading room will be opened up to the public.

It also shows another major milestone in that the shell of Site 2C will now be complete and be being fitted out. This will allow the full extent of the pedestrian route between Site 2AB and 2C to be opened for public use linking Moore Street to O'Connell Street. Site 4 North now opens to the public as access through the new square is provided.

The Station fit out continues.



| 2022 |    |    |    | 2023 |    |    |    | 2024 |    |    |    | 2025 |    |    |    | 2026 |    |    |    | 2027 |    |    |    | 2028 |    |    |    | 2029 |    |    |    | 2030 |    |    |    | 2031 |    |    |    | 2032 |    |    |    | 2033 |  |  |  |  |  |  |  |
|------|----|----|----|------|----|----|----|------|----|----|----|------|----|----|----|------|----|----|----|------|----|----|----|------|----|----|----|------|----|----|----|------|----|----|----|------|----|----|----|------|----|----|----|------|--|--|--|--|--|--|--|
| Q1   | Q2 | Q3 | Q4 | Q1   | Q2 | Q3 | Q4 | Q1   | Q2 | Q3 | Q4 | Q1   | Q2 | Q3 | Q4 | Q1   | Q2 | Q3 | Q4 | Q1   | Q2 | Q3 | Q4 | Q1   | Q2 | Q3 | Q4 | Q1   | Q2 | Q3 | Q4 | Q1   | Q2 | Q3 | Q4 | Q1   | Q2 | Q3 | Q4 | Q1   | Q2 | Q3 | Q4 |      |  |  |  |  |  |  |  |
|      |    |    |    |      |    |    |    |      |    |    |    |      |    |    |    |      |    |    |    |      |    |    |    |      |    |    |    |      |    |    |    |      |    |    |    |      |    |    |    |      |    |    |    |      |  |  |  |  |  |  |  |



PRELIMINARY PROJECT PROGRAMME – INDICATIVE ONLY

Principal activities taking place:

This image shows the works continuing with the construction of Site 5

The Station is now being commissioned.



**APPENDIX C**

**Site 2 – Temporary Works**



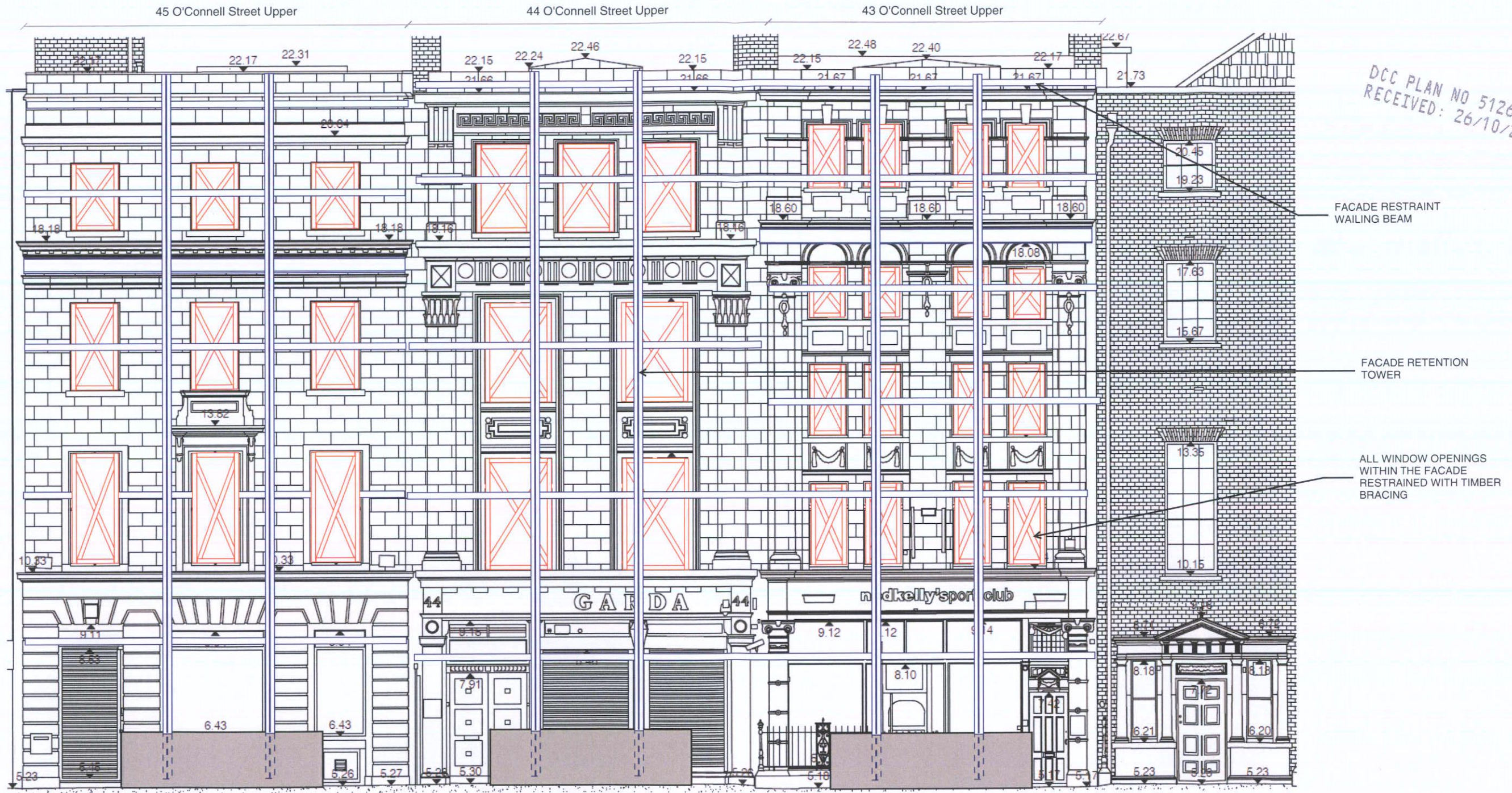

DCC PLAN NO 5126/22  
RECEIVED: 26/10/2022

43-45 O'Connell Street Upper - Elevation  
SCALE 1:100

**GENERAL NOTES**

- THIS DRAWING IS COPYRIGHT AND THE PROPERTY OF WATERMAN MOYLAN AND IS NOT TO BE COPIED IN WHOLE OR IN PART UNLESS UNDER WRITTEN AGREEMENT.
- DO NOT SCALE FROM THIS DRAWING. WORK TO FIGURED DIMENSIONS ONLY.
- THIS DRAWING IS TO BE READ IN CONJUNCTION WITH THE ARCHITECT'S AND OTHER DESIGN TEAM'S DRAWINGS AND SPECIFICATIONS

**Waterman Moylan**  
Engineering Consultants

East Point Business Park Dublin D03 H3F4  
t +353 1 664 8900  
info@moylan.ie www.waterman-moylan.ie

|         |                |  |                           |
|---------|----------------|--|---------------------------|
| TITLE   |                | 43-45 O'Connell Street - Retained Facade Elevation |                           |
| PROJECT | Dublin Central | CLIENT   | Dublin Central GP Limited |

|                   |        |                   |            |
|-------------------|--------|-------------------|------------|
| DRAWING STATUS    |        | INFORMATION       |            |
| DRAWN             | RN     | DESIGNED          | RN         |
| CHECKED           | RO     | DATE              | 02.07.2021 |
| PROJECT           | 19-021 | SCALE             | 1:100      |
| DRAWING REFERENCE |        | WM-ZZ-ZZ-SK-S-008 |            |

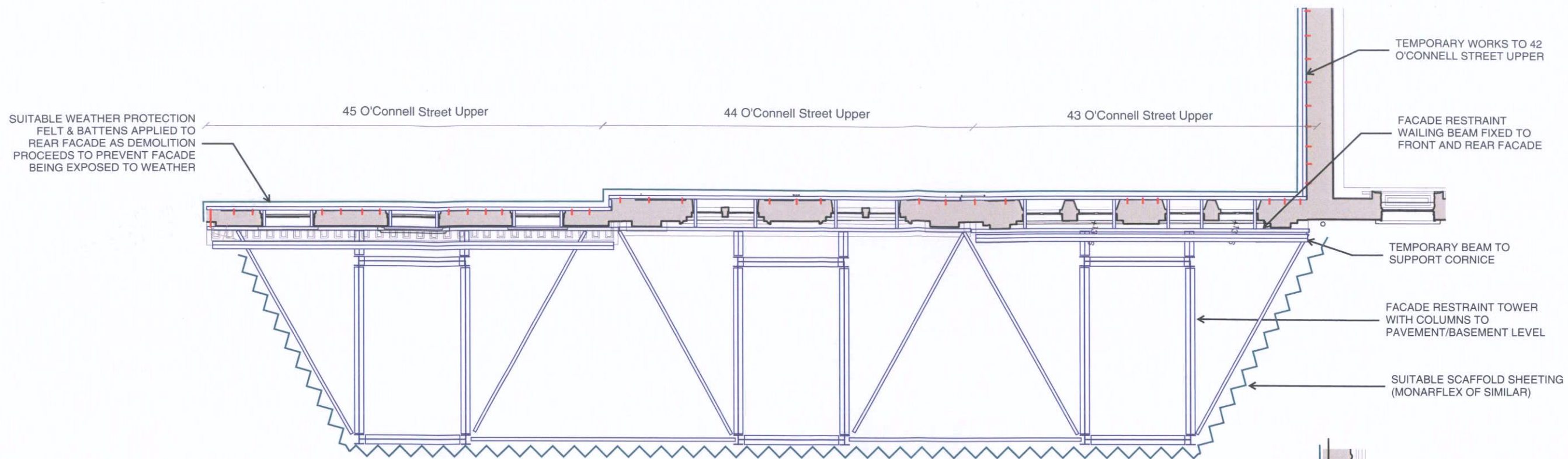

43-45 O'Connell Street Upper - Level 3 Plan  
SCALE 1:100

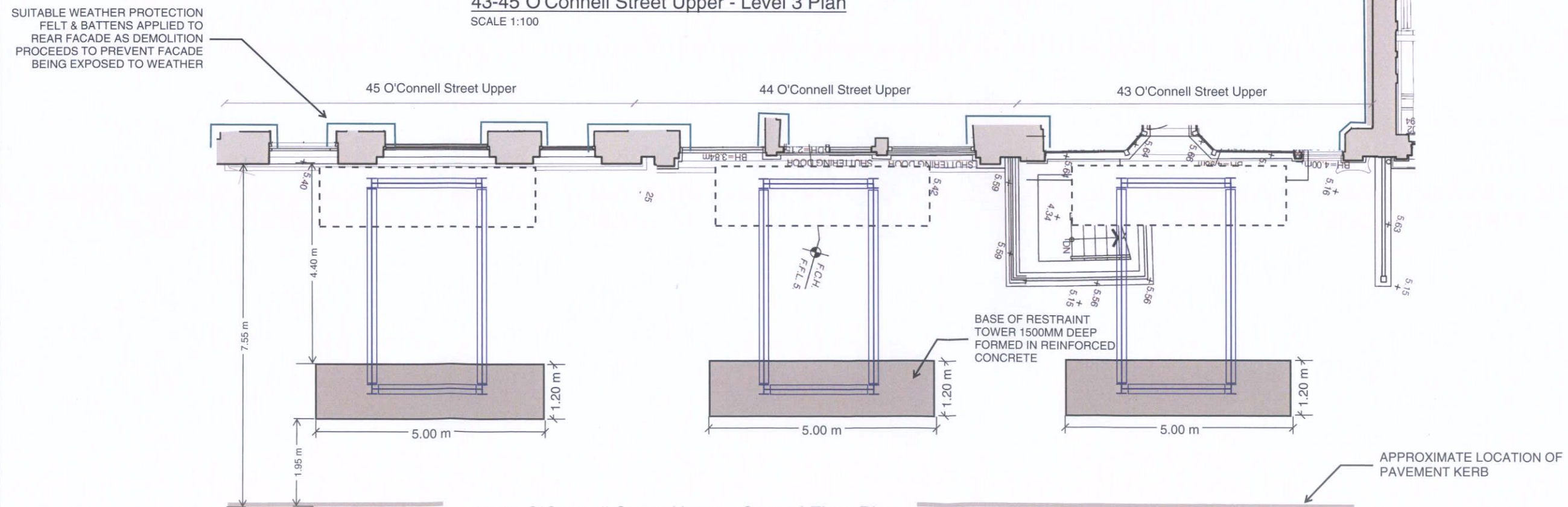

43-45 O'Connell Street Upper - Ground Floor Plan  
SCALE 1:100

GENERAL NOTES

- THIS DRAWING IS COPYRIGHT AND THE PROPERTY OF "WATERMAN MOYLAN" AND IS NOT TO BE COPIED IN WHOLE OR IN PART UNLESS UNDER WRITTEN AGREEMENT.
- DO NOT SCALE FROM THIS DRAWING. WORK TO FIGURED DIMENSIONS ONLY.
- THIS DRAWING IS TO BE READ IN CONJUNCTION WITH THE ARCHITECT'S AND OTHER DESIGN TEAM'S DRAWINGS AND SPECIFICATIONS

**Waterman Moylan**  
Engineering Consultants  
East Point Business Park Dublin D03 H3F4  
1+353 1 664 8900  
info@moylean.ie www.waterman-moylan.ie

TITLE

43-45 O'Connell Street - Retained  
Facade Plans

PROJECT

Dublin Central

CLIENT

Dublin Central GP Limited

DRAWING STATUS

| DRAWING STATUS |        | INFORMATION |            |
|----------------|--------|-------------|------------|
| DRAWN          | RN     | DESIGNED    | RN         |
| PROJECT        | 19-021 | DATE        | 02.07.2021 |
| CHECKED        | RO     | SCALE       | 1:100      |

DRAWING REFERENCE

WM-ZZ-ZZ-SK-S-009

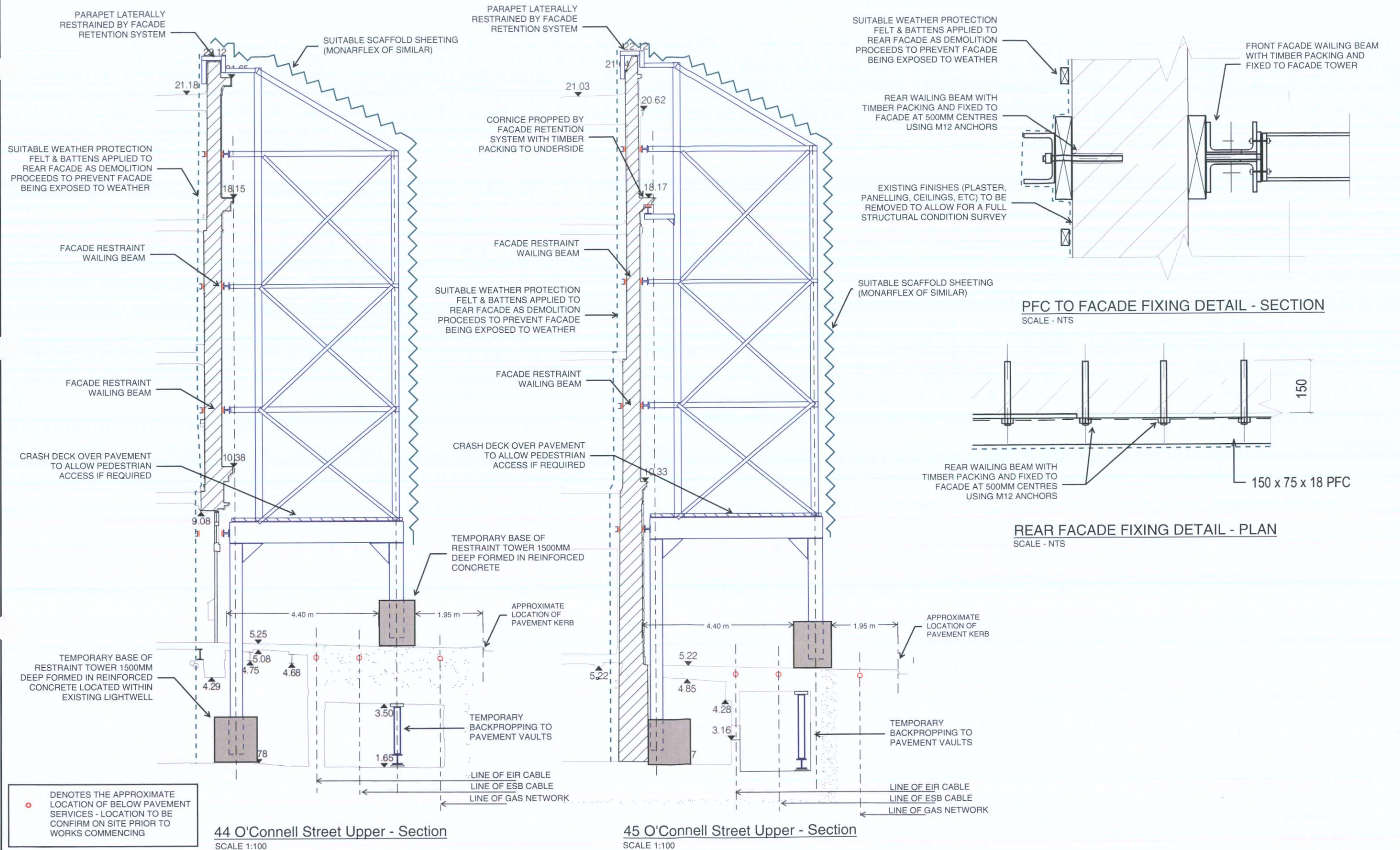

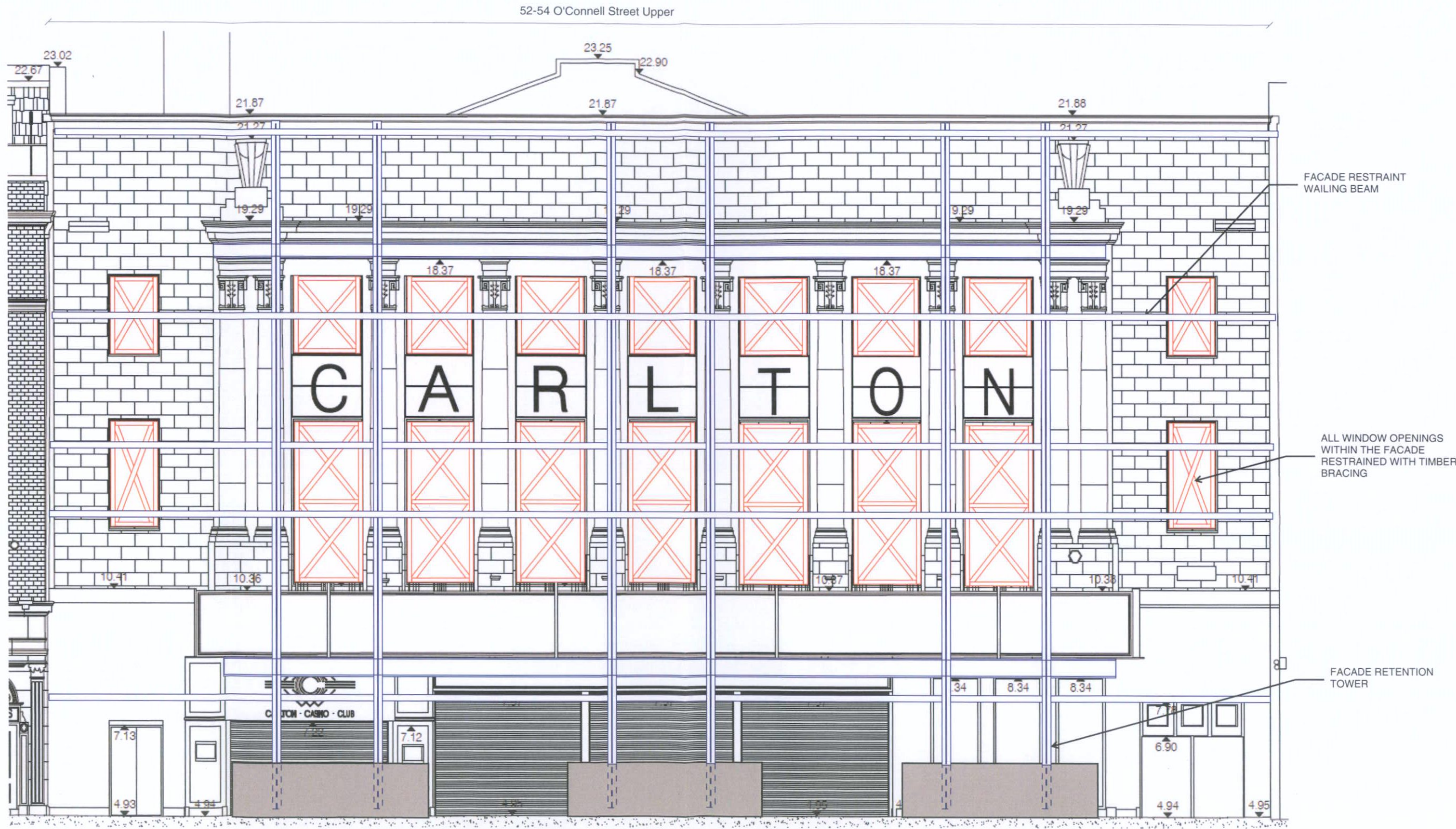

52-54 O'Connell Street Upper - Elevation  
SCALE 1:100

**GENERAL NOTES**

1. THIS DRAWING IS COPYRIGHT AND THE PROPERTY OF "WATERMAN MOYLAN" AND IS NOT TO BE COPIED IN WHOLE OR IN PART UNLESS UNDER WRITTEN AGREEMENT.
2. DO NOT SCALE FROM THIS DRAWING. WORK TO FIGURED DIMENSIONS ONLY.
3. THIS DRAWING IS TO BE READ IN CONJUNCTION WITH THE ARCHITECT'S AND OTHER DESIGN TEAM'S DRAWINGS AND SPECIFICATIONS

**Waterman Moylan**  
Engineering Consultants

East Point Business Park Dublin D03 H3F4  
t+353 1 664 8900  
info@moylan.ie www.waterman-moylan.ie

**TITLE**

52-54 O'Connell Street - Retained  
Facade Elevation

PROJECT  
Dublin Central

CLIENT  
Dublin Central GP Limited

**DRAWING STATUS**

|         |        |          |            |         |       |
|---------|--------|----------|------------|---------|-------|
| DRAWN   | RN     | DESIGNED | RN         | CHECKED | RO    |
| PROJECT | 19-021 | DATE     | 05.07.2021 | SCALE   | 1:100 |

**INFORMATION**

DRAWING REFERENCE  
WM-ZZ-ZZ-SK-S-011

SUITABLE WEATHER PROTECTION  
FELT & BATTENS APPLIED TO  
REAR FACADE AS DEMOLITION  
PROCEEDS TO PREVENT FACADE  
BEING EXPOSED TO WEATHER

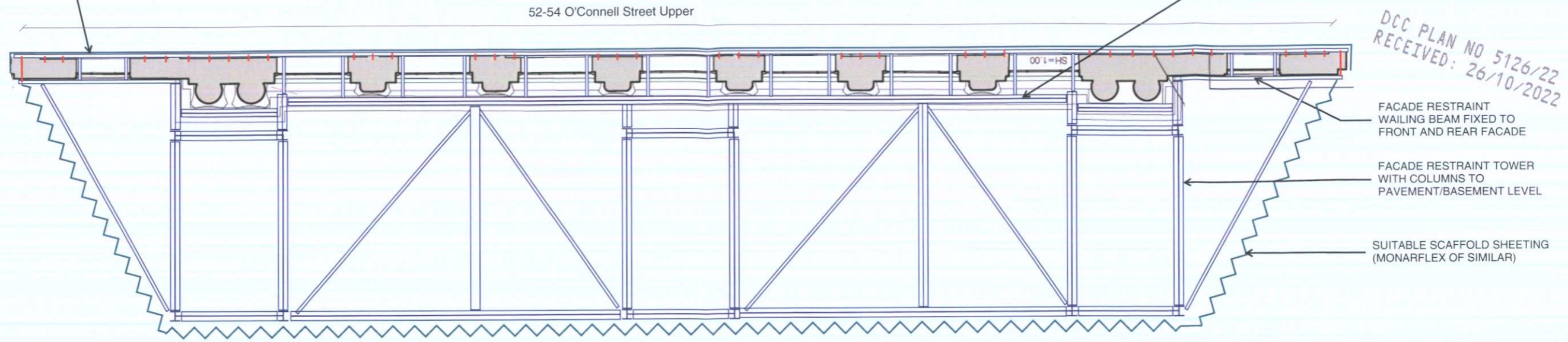

DCC PLAN NO 5126/22  
RECEIVED: 26/10/2022

FACADE RESTRAINT  
WAILING BEAM FIXED TO  
FRONT AND REAR FACADE

FACADE RESTRAINT TOWER  
WITH COLUMNS TO  
PAVEMENT/BASEMENT LEVEL

SUITABLE SCAFFOLD SHEETING  
(MONARFLEX OF SIMILAR)

52-54 O'Connell Street Upper - Level 3 Plan  
SCALE 1:100

SUITABLE WEATHER PROTECTION  
FELT & BATTENS APPLIED TO  
REAR FACADE AS DEMOLITION  
PROCEEDS TO PREVENT FACADE  
BEING EXPOSED TO WEATHER

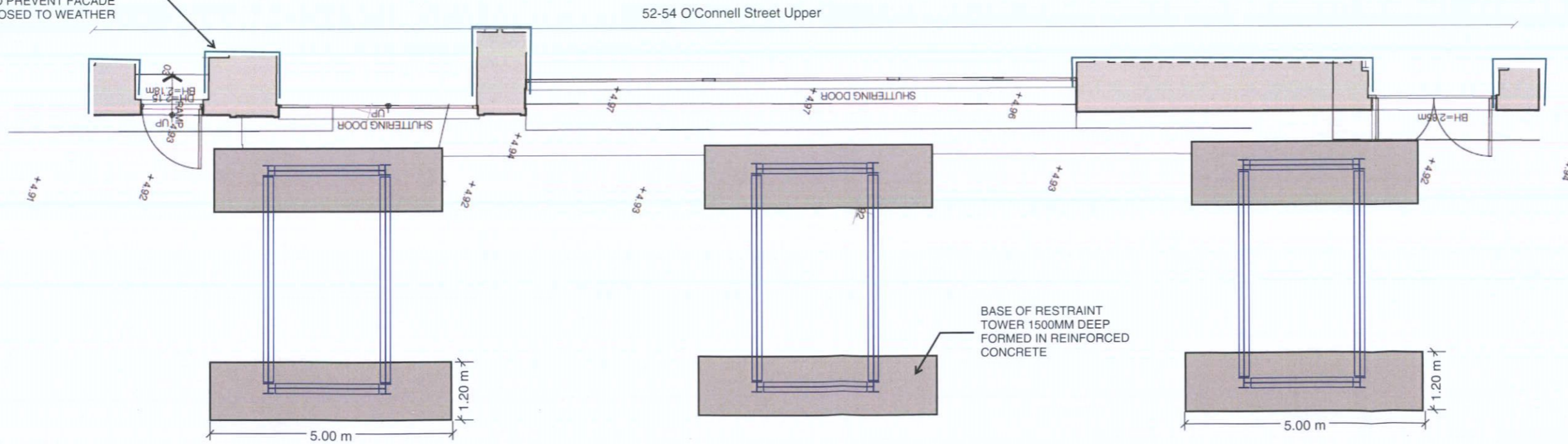

BASE OF RESTRAINT  
TOWER 1500MM DEEP  
FORMED IN REINFORCED  
CONCRETE

52-54 O'Connell Street Upper - Ground Floor Plan  
SCALE 1:100

GENERAL NOTES

- THIS DRAWING IS COPYRIGHT AND THE PROPERTY OF "ATERMAN MOYLAN" AND IS NOT TO BE COPIED IN WHOLE OR IN PART UNLESS UNDER WRITTEN AGREEMENT.
- DO NOT SCALE FROM THIS DRAWING. WORK TO FIGURED DIMENSIONS ONLY.
- THIS DRAWING IS TO BE READ IN CONJUNCTION WITH THE ARCHITECT'S AND OTHER DESIGN TEAM'S DRAWINGS AND SPECIFICATIONS

**Waterman Moylan**  
Engineering Consultants  
East Point Business Park Dublin D03 H3F4  
t +353 1 664 8900  
info@moylan.ie www.waterman-moylan.ie

TITLE

52-54 O'Connell Street - Retained  
Facade Plans

PROJECT

Dublin Central

CLIENT

Dublin Central GP Limited

DRAWING STATUS

DRAWN RN  
PROJECT 19-021

INFORMATION

|                 |             |
|-----------------|-------------|
| DESIGNED RN     | CHECKED RO  |
| DATE 05.07.2021 | SCALE 1:100 |

DRAWING REFERENCE

WM-ZZ-ZZ-SK-S-012

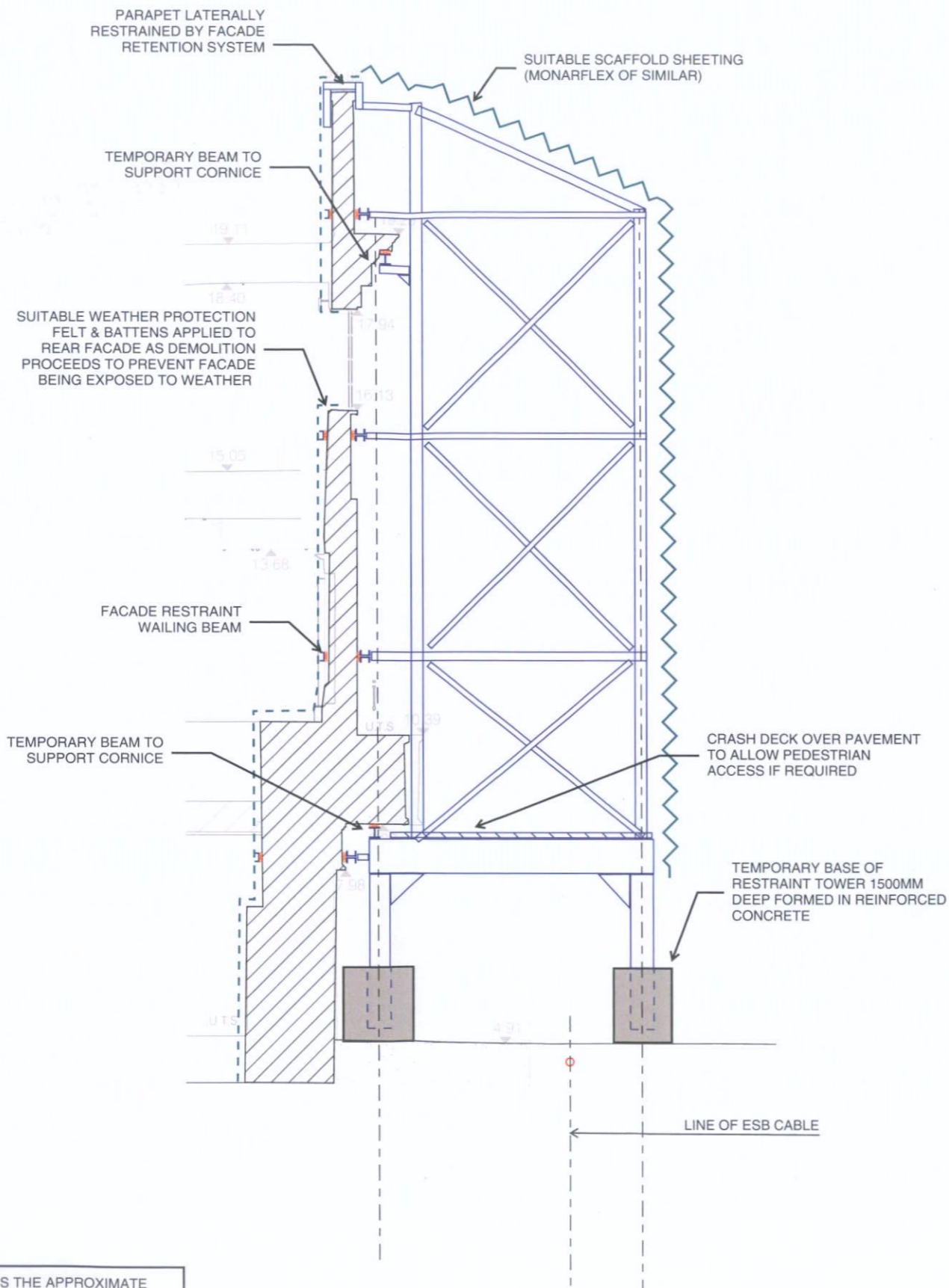

52-54 O'Connell Street Upper - Section  
SCALE 1:100

○ DENOTES THE APPROXIMATE LOCATION OF BELOW PAVEMENT SERVICES - LOCATION TO BE CONFIRMED ON SITE PRIOR TO WORKS COMMENCING

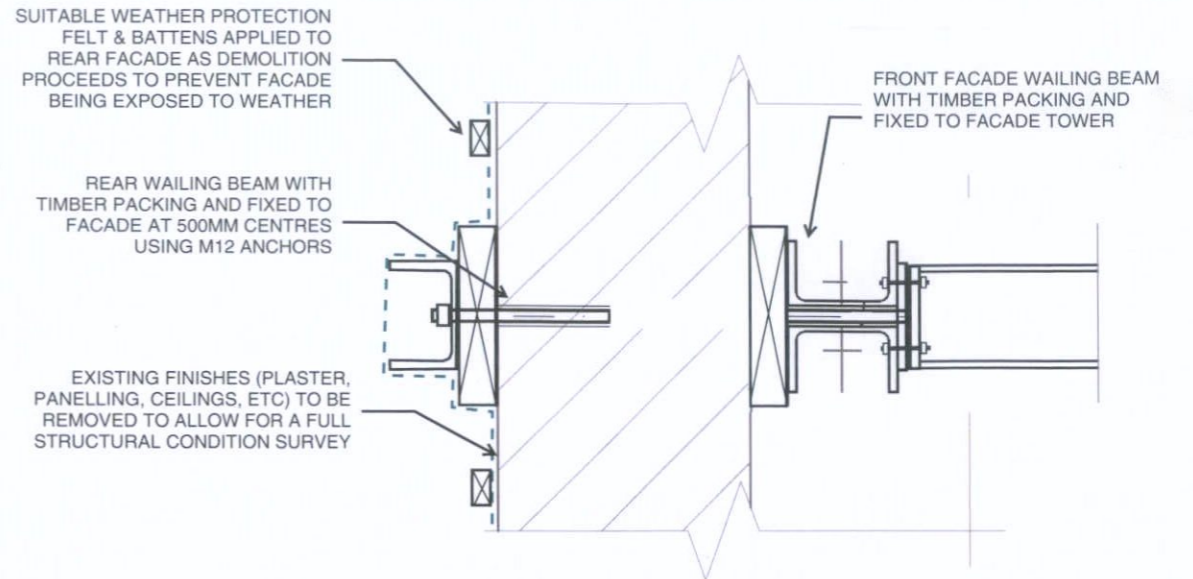

PFC TO FACADE FIXING DETAIL - SECTION  
SCALE - NTS

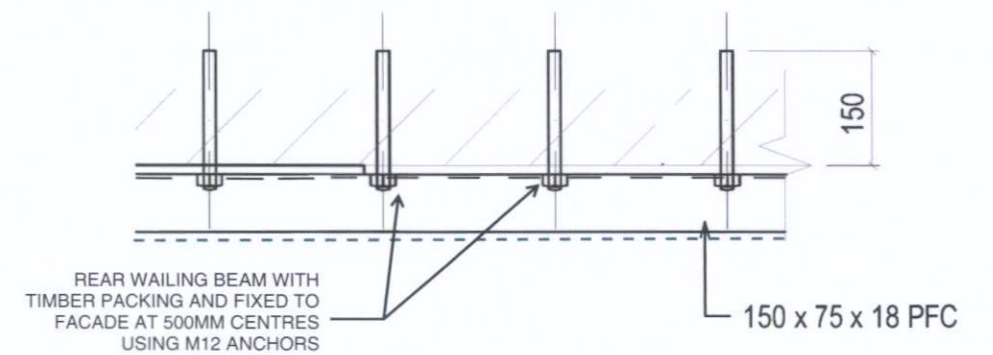

REAR FACADE FIXING DETAIL - PLAN  
SCALE - NTS

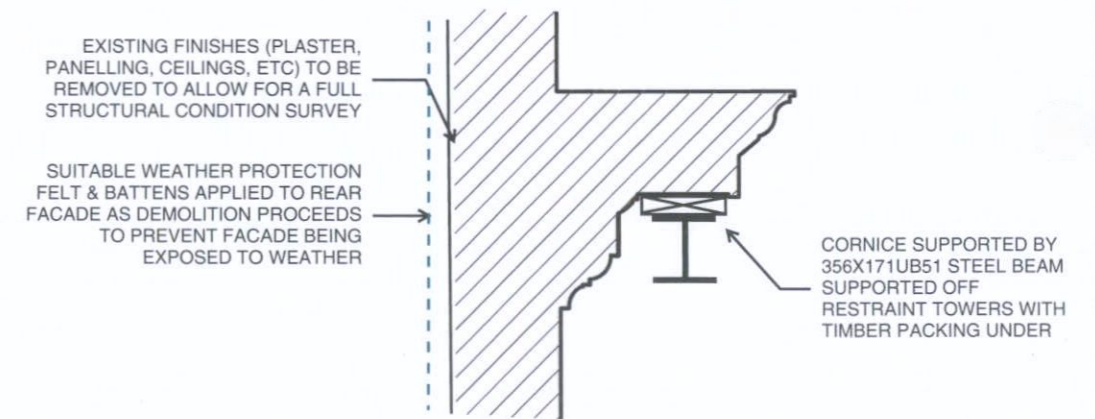

CORNICE SUPPORT DETAIL - SECTION  
SCALE - NTS

GENERAL NOTES

- THIS DRAWING IS COPYRIGHT AND THE PROPERTY OF "WATERMAN MOYLAN" AND IS NOT TO BE COPIED IN WHOLE OR IN PART UNLESS UNDER WRITTEN AGREEMENT.
- DO NOT SCALE FROM THIS DRAWING. WORK TO FIGURED DIMENSIONS ONLY.
- THIS DRAWING IS TO BE READ IN CONJUNCTION WITH THE ARCHITECT'S AND OTHER DESIGN TEAM'S DRAWINGS AND SPECIFICATIONS

**Waterman Moylan**  
Engineering Consultants  
East Point Business Park Dublin D03 H3F4  
t +353 1 664 8900  
info@moylan.ie www.waterman-moylan.ie

TITLE

52-54 O'Connell Street - Retained  
Facade Section & Details

PROJECT

Dublin Central

CLIENT

Dublin Central GP Limited

DRAWING STATUS

INFORMATION

|         |        |          |            |         |       |
|---------|--------|----------|------------|---------|-------|
| DRAWN   | RN     | DESIGNED | RN         | CHECKED | RO    |
| PROJECT | 19-021 | DATE     | 05.07.2021 | SCALE   | 1:100 |

DRAWING REFERENCE

WM-ZZ-ZZ-SK-S-013

DCC PLAN NO 5126/22  
RECEIVED: 26/10/2022

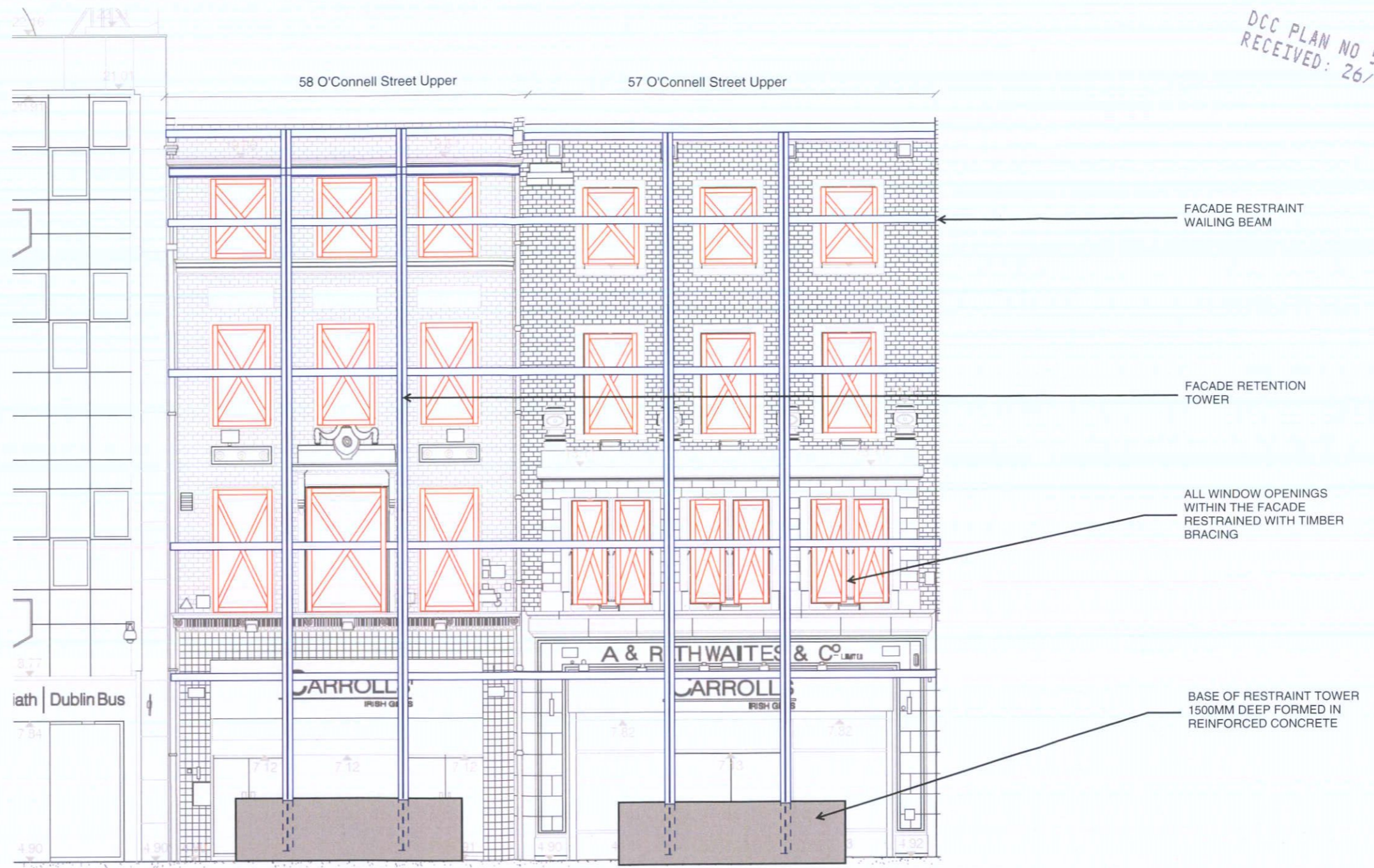

57-58 O'Connell Street Upper - Elevation  
SCALE 1:100

GENERAL NOTES

- THIS DRAWING IS COPYRIGHT AND THE PROPERTY OF 'ATERMAN MOYLAN' AND IS NOT TO BE COPIED IN WHOLE OR IN PART UNLESS UNDER WRITTEN AGREEMENT.
- DO NOT SCALE FROM THIS DRAWING. WORK TO FIGURED DIMENSIONS ONLY.
- THIS DRAWING IS TO BE READ IN CONJUNCTION WITH THE ARCHITECT'S AND OTHER DESIGN TEAM'S DRAWINGS AND SPECIFICATIONS

**Waterman Moylan**  
Engineering Consultants

East Point Business Park Dublin D03 H3F4  
1 +353 1 664 8900  
info@moylan.ie www.waterman-moylan.ie

TITLE

57-58 O'Connell Street - Retained  
Facade Elevation

PROJECT

Dublin Central

CLIENT

Dublin Central GP Limited

DRAWING STATUS

DRAWN RN  
PROJECT 19-021

INFORMATION

DESIGNED RN  
DATE 08.07.2021  
CHECKED RO  
SCALE 1:100

DRAWING REFERENCE

WM-ZZ-ZZ-SK-S-014

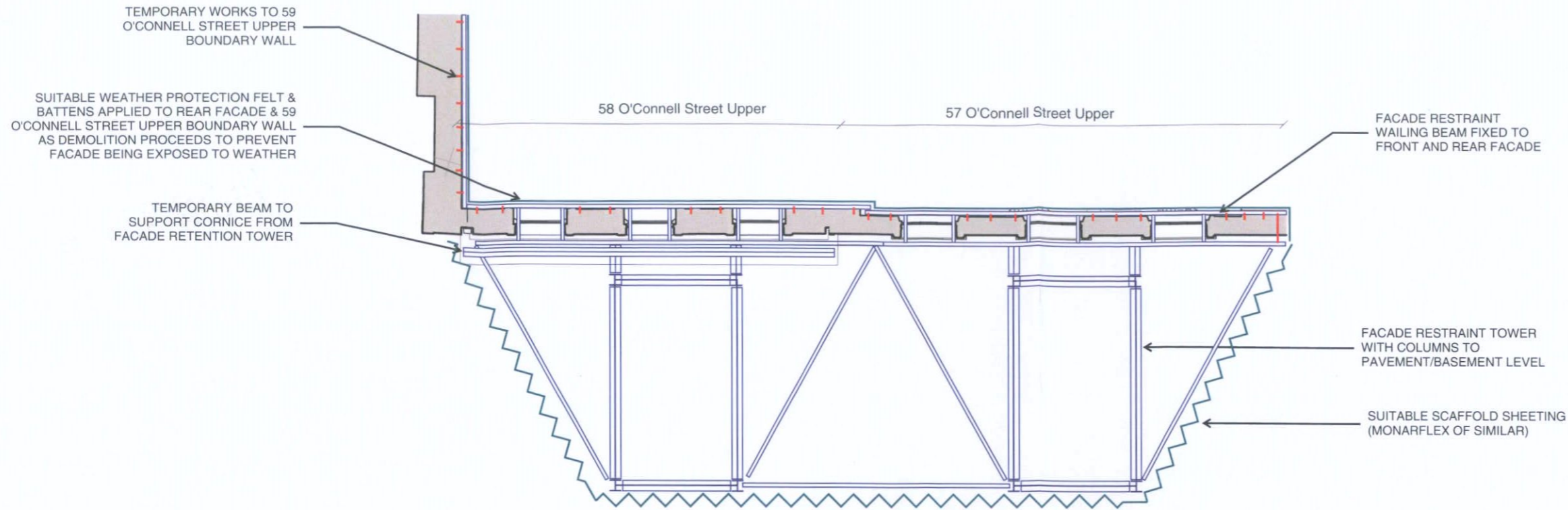

57-58 O'Connell Street Upper - Level 3 Plan  
SCALE 1:100

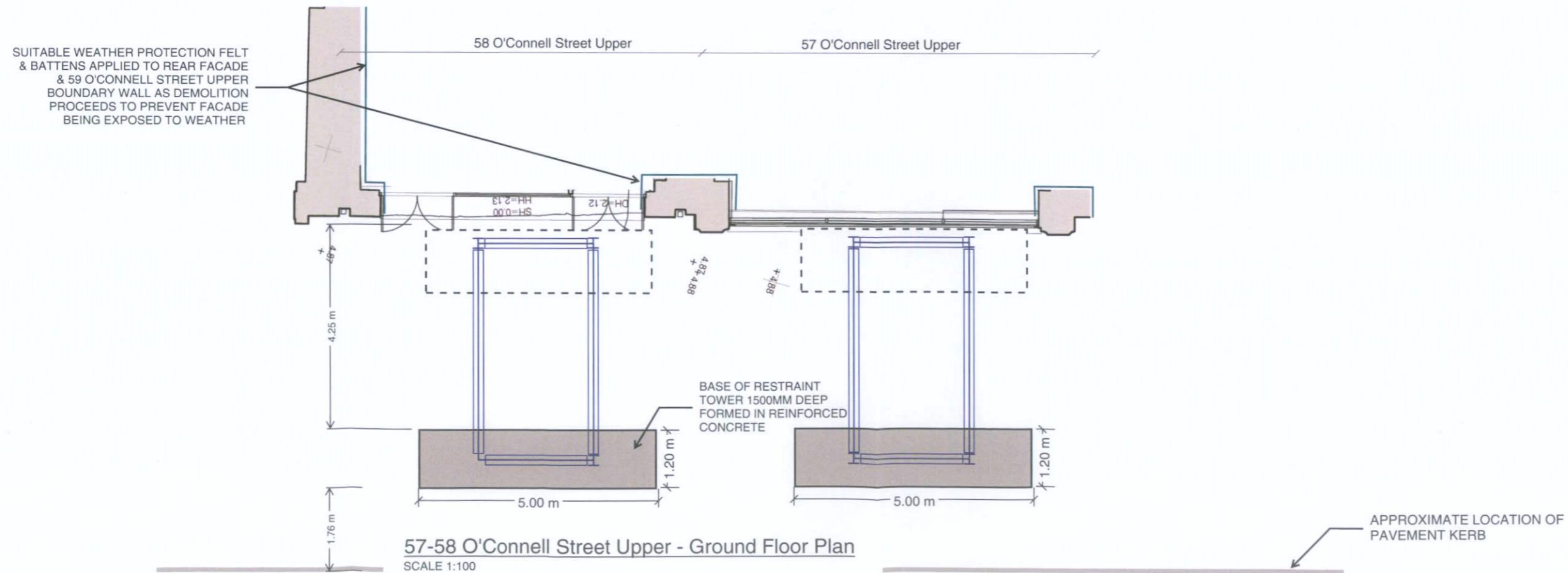

57-58 O'Connell Street Upper - Ground Floor Plan  
SCALE 1:100

GENERAL NOTES

1. THIS DRAWING IS COPYRIGHT AND THE PROPERTY OF "WATERMAN MOYLAN" AND IS NOT TO BE COPIED IN WHOLE OR IN PART UNLESS UNDER WRITTEN AGREEMENT.
2. DO NOT SCALE FROM THIS DRAWING. WORK TO FIGURED DIMENSIONS ONLY.
3. THIS DRAWING IS TO BE READ IN CONJUNCTION WITH THE ARCHITECT'S AND OTHER DESIGN TEAM'S DRAWINGS AND SPECIFICATIONS

**Waterman Moylan**  
Engineering Consultants  
East Point Business Park Dublin D03 H3F4  
t +353 1 664 8900  
info@moylan.ie www.waterman-moylan.ie

TITLE

57-58 O'Connell Street - Retained  
Facade Plans

PROJECT

Dublin Central

CLIENT

Dublin Central GP Limited

DRAWING STATUS

DRAWN RN  
PROJECT 19-021

INFORMATION

DESIGNED RN  
CHECKED RO  
DATE 08.07.2021  
SCALE 1:100

DRAWING REFERENCE

WM-ZZ-ZZ-SK-S-015



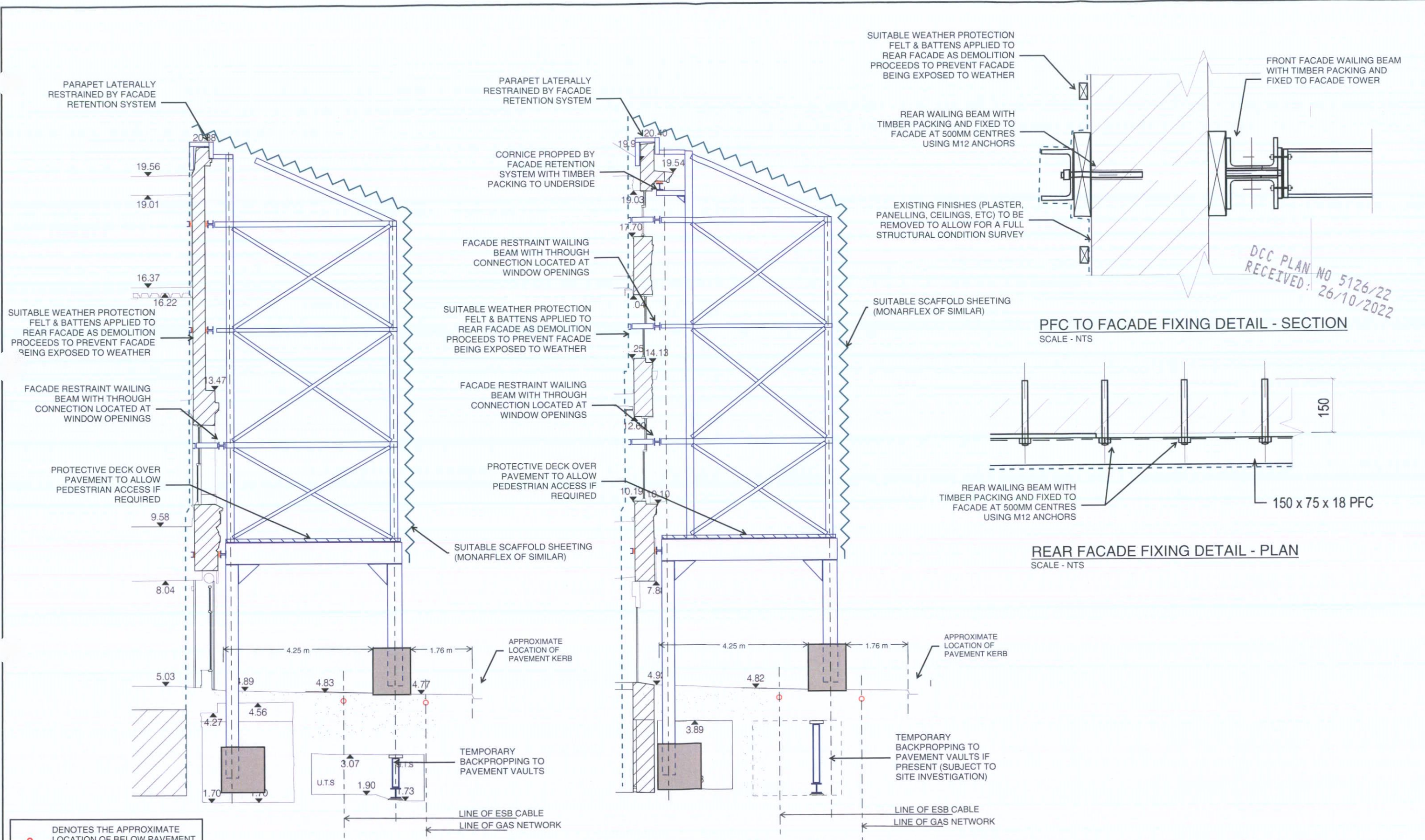

DCC PLAN NO 5126/22  
RECEIVED: 26/10/2022

○ DENOTES THE APPROXIMATE LOCATION OF BELOW PAVEMENT SERVICES - LOCATION TO BE CONFIRMED ON SITE PRIOR TO WORKS COMMENCING

57 O'Connell Street Upper - Section  
SCALE 1:100

58 O'Connell Street Upper - Section  
SCALE 1:100

**GENERAL NOTES**

1. THIS DRAWING IS COPYRIGHT AND THE PROPERTY OF "WATERMAN MOYLAN" AND IS NOT TO BE COPIED IN WHOLE OR IN PART UNLESS UNDER WRITTEN AGREEMENT.

DO NOT SCALE FROM THIS DRAWING. WORK TO FIGURED DIMENSIONS ONLY.

3. THIS DRAWING IS TO BE READ IN CONJUNCTION WITH THE ARCHITECT'S AND OTHER DESIGN TEAM'S DRAWINGS AND SPECIFICATIONS

**Waterman Moylan**  
Engineering Consultants

East Point Business Park Dublin D03 H3F4  
t+353 1 664 8900  
info@moylan.ie www.waterman-moylan.ie

|  |                |                |                           |                   |            |
|--|----------------|----------------|---------------------------|-------------------|------------|
| TITLE  |                | DRAWING STATUS |                           | INFORMATION       |            |
| 57-58 O'Connell Street - Retained Facade Section & Details |                | DRAWN          | RN                        | DESIGNED          | RN         |
|  |                | CHECKED        | RO                        | DATE              | 08.07.2021 |
| PROJECT  | Dublin Central | CLIENT         | Dublin Central GP Limited | SCALE             | 1:100      |
| DRAWING REFERENCE  |                |                |                           | WM-ZZ-ZZ-SK-S-016 |            |

**APPENDIX 3.3      OUTLINE CONSTRUCTION & DEMOLITION MANAGEMENT PLAN – NO.  
61 O'CONNELL STREET UPPER**

DCC PLAN NO 5126/22  
RECEIVED: 26/10/2022

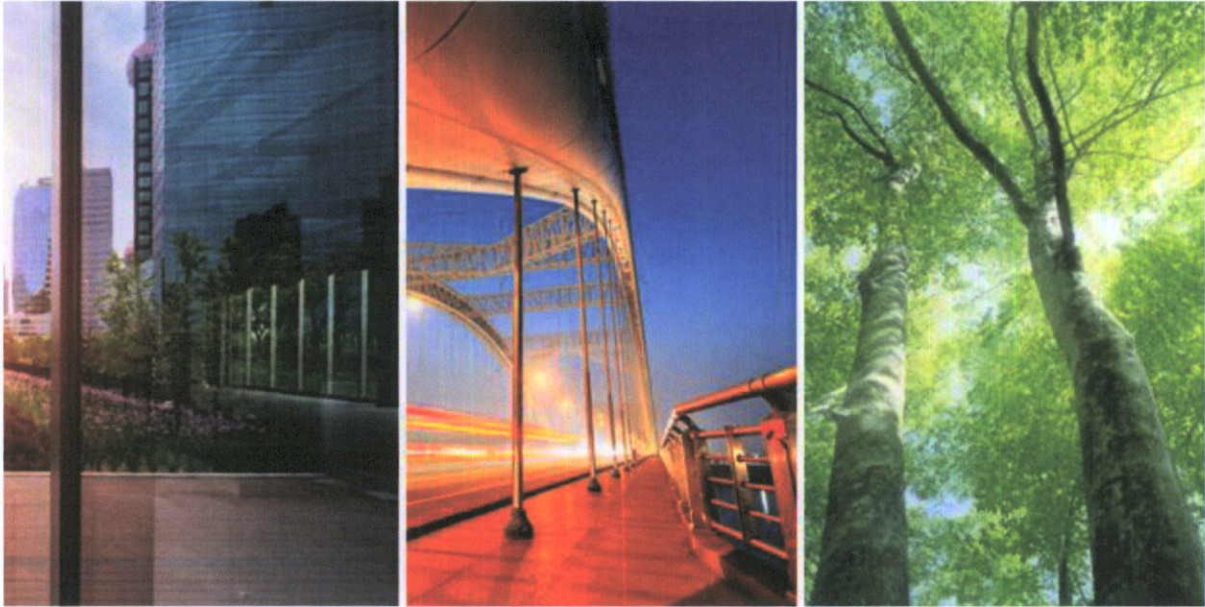

## **Outline Construction & Demolition Management Plan**

61 O'Connell Street Upper

Dublin Central GP Limited

DC-WAT-2D-XX-RP-C-001013

September 2022

**Waterman Moylan Consulting Engineers Limited**

Block S, East Point Business Park, Alfie Byrne Road, Dublin D03 H3F4  
[www.waterman-moylan.ie](http://www.waterman-moylan.ie)



**Waterman Moylan**  
Engineering Consultants

**Client Name:** Dublin Central GP Limited  
**Document Reference:** DC-WAT-2D-XX-RP-C-001013  
**Project Number:** 19-021

### Quality Assurance – Approval Status

This document has been prepared and checked in accordance with  
Waterman Group's IMS (BS EN ISO 9001: 2015 and BS EN ISO 14001: 2015)

---

| <b>Issue</b> | <b>Date</b>       | <b>Prepared by</b> | <b>Checked by</b> | <b>Approved by</b>    |
|--------------|-------------------|--------------------|-------------------|-----------------------|
| P1           | 28 September 2022 | R. Nelson          | C. Beresford      | <i>Joseph Gibbons</i> |

**Comments**

---

## Disclaimer

This report has been prepared by Waterman Moylan, with all reasonable skill, care and diligence within the terms of the Contract with the Client, incorporation of our General Terms and Condition of Business and taking account of the resources devoted to us by agreement with the Client.

We disclaim any responsibility to the Client and others in respect of any matters outside the scope of the above.

This report is confidential to the Client and we accept no responsibility of whatsoever nature to third parties to whom this report, or any part thereof, is made known. Any such party relies on the report at its own risk.

# Contents

- 1. Introduction.....1**
  - 1.1 Site Location .....2
  - 1.2 Building History .....2
- 2. Proposed Refurbishment Works.....4**
  - 2.1 Roof Level .....4
  - 2.2 Third & Second Floor .....4
  - 2.3 First Floor .....5
  - 2.4 Ground Floor .....5
  - 2.5 Basement Level .....5
- 3. Site Setup .....6**
  - 3.1.1 Perimeter Hoarding .....6
  - 3.1.2 Site Compound .....7
  - 3.1.3 Access & Egress .....7
  - 3.1.4 Logistics .....7
  - 3.1.5 Proposed Craneage Strategy .....8
  - 3.1.6 Power, Waste & Drainage .....8
  - 3.1.7 Working Hours .....8
  - 3.1.8 Car Parking .....9
  - 3.1.9 Expected Vehicle Movement .....9
  - 3.1.10 Security .....9
- 4. Construction Methodology:.....10**
  - 4.1 Enabling Works .....10
  - 4.2 Demolition Works .....10
  - 4.3 Repair Works to Existing Walls .....10
  - 4.4 Repair Works to Existing Floors .....11
  - 4.5 Repair Works to Existing Roof .....11
- 5. Construction and Demolition Waste Management .....13**
  - 5.1 Non-Hazardous Construction Waste .....13
  - 5.2 Potential Hazardous Wastes Arising.....14
    - 5.2.1 Contaminated Material .....14
    - 5.2.2 Fuel/Oils .....14
    - 5.2.3 Asbestos .....14
    - 5.2.4 Other known Hazardous Substances .....14
  - 5.3 Appointment of C&D Waste Manager .....14
  - 5.4 C&D Record Keeping .....15
  - 5.5 Surface Water Protection .....15
- 6. Movement Monitoring .....16**

|           |   |           |
|-----------|---|-----------|
| 6.1.1     | Overview .....  | 16        |
| 6.1.2     | Proposed Monitoring Regime .....  | 16        |
| <b>7.</b> | <b>Control and Monitoring of Noise, Vibration and Dust on site.....</b>               | <b>17</b> |
| 7.1       | Condition Surveys .....   | 17        |
| 7.2       | Noise Monitoring .....  | 17        |
| 7.2.1     | Measures to Mitigate Noise .....  | 18        |
| 7.3       | Vibration .....   | 18        |
| 7.3.1     | Proposed works and potential risks .....  | 18        |
| 7.3.2     | Vibrations Standards.....   | 19        |
| 7.3.3     | Impact of ground borne vibrations arising from Proposed works .....                   | 19        |
| 7.3.4     | Mitigation Measures to be put in place prior to works.....                            | 20        |
| 7.3.5     | Monitoring and Mitigation for Ground borne Vibrations during Construction Works ..... | 21        |
| 7.4       | Air & Dust Management.....  | 21        |
| <b>8.</b> | <b>Building Control Amendment Regulations .....</b>                                   | <b>23</b> |
| 8.1       | Quality Assurance during Construction and BC(A)R Compliance.....                      | 23        |
| <b>9.</b> | <b>Liaison with Third Parties .....</b>   | <b>24</b> |

## **1. Introduction**

Waterman Moylan have prepared the following Outline Construction and Demolition Management Plan for the implementation of the demolition and construction stages of the proposed refurbishment work to 61 O'Connell Street Upper.

The following Outline Construction and Demolition Management Plan sets out typical arrangements and measures which may be undertaken during the demolition and construction stages of the project in order to mitigate and minimise disruption and disturbance to the area around the site.

This Outline Construction and Demolition Management Plan will be used to guide the Contractor who will have ultimate responsibility for developing a more detailed demolition and construction management plan for formal agreement with Dublin City Council in advance of them commencing the demolition or construction works on site. This plan will provide Dublin City Council with an outline proposal of how construction will be managed to comply with Local Authority and statutory requirements and will be updated post award of planning to reflect specific planning conditions which may be applied to the development.

This plan should be read in conjunction with all other planning stage reports included as part of this planning application.



## 1.1 Site Location

The subject site is located within the Dublin Central Project Masterplan development area. The Masterplan area encompasses almost entirely three urban blocks. The area is bounded generally by O'Connell Street Upper and Henry Place to the east, Henry Street to the south, Moore Street to the west, and O'Rahilly Parade and Parnell Street to the north. Moore Lane extends south from Parnell Street through the centre of the masterplan area, as far as its junction with Henry Place.

The subject site is at the east of the Masterplan area and is bounded to the east by O'Connell Street Upper, to the west by Henry Place, to the north by 60 O'Connell Street Upper and to the south by 62 O'Connell Street Upper. The building forms part of the terraced street frontage, and no.'s 60 to the north and 62 to the south are period buildings. Portions of the subject structure are listed/protected.

Of particular importance with respect to the site are:

- The protected upper front façade of 61 O'Connell Street Upper
- Occupied buildings of 60 O'Connell Street Upper and 62 O'Connell Street Upper
- Direct site access to O'Connell Street Upper and Henry Place

The site location is indicated in the Figure below:

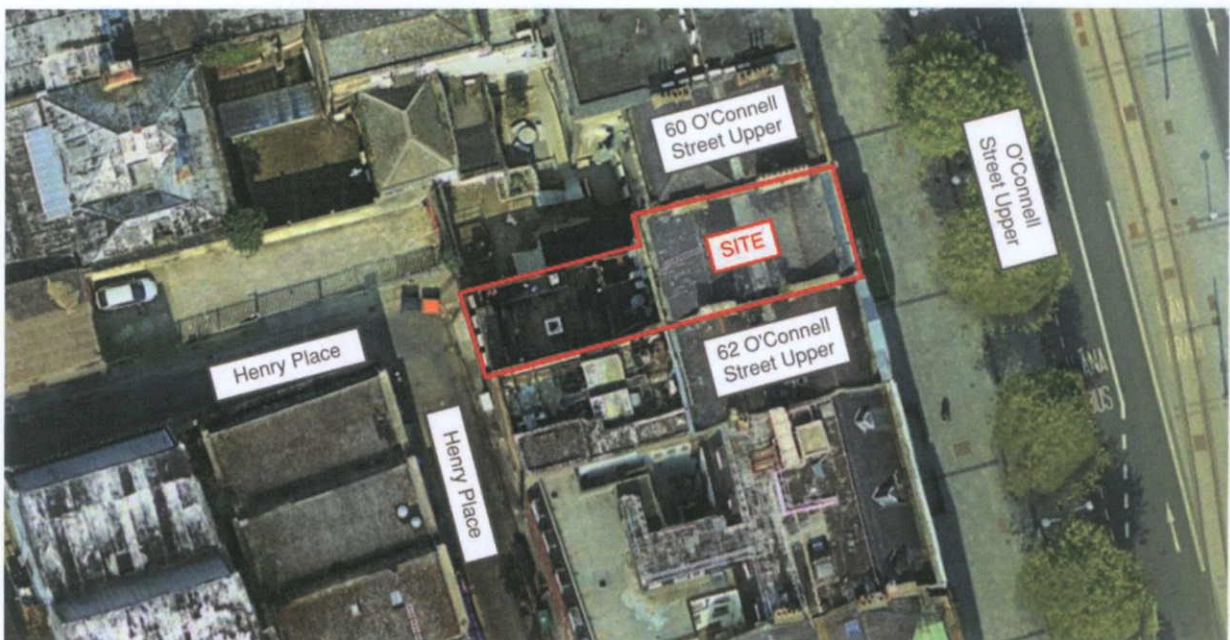

**Figure 1** | Site Location (Source: Google Maps)

## 1.2 Building History

The building was constructed in the 1760's for residential use. This continued until the 1850's, when it appears to have changed use to accommodate a local solicitor's office. Records from 1893 show the 4-storey building on the street frontage and a single storey addition to the rear, though it is not known when this was added.

Various uses followed, with insurance companies, publishers and chemists all having been in occupation through to the 1980's. In 1913, when the chemist took occupancy, significant alterations were made, and

the ground floor of the main 4-storey structure was opened up by the introduction of a rivetted plate girder that is still evident today. The current restaurant Flannigan's has been in occupation since the 1908's.

The building forms part of the terraced street frontage, No 61 sits between period buildings Nos. 60 and 62-63 O'Connell Street Upper.

## 2. Proposed Refurbishment Works

The proposed refurbishment comprises residential accommodation over 4-storeys, all over the existing single-storey basement. A new pedestrian through-route is proposed at ground floor, linking between O'Connell Street Upper and Henry Place/Moore Lane. A café/restaurant is proposed at ground floor level, while the basement is to be utilised as a gym/studio space with changing facilities. An external area to the rear will replace the existing single-storey extension, to provide cycle and refuse storage areas.

The Schedule of Accommodation is set out in the Table below:

| Description       | Total  |
|-------------------|--|
| Residential       | 3 No. 2-Bed Apartments (cumulative area of 294m <sup>2</sup> ) |
| Gym/Studio        | 206m <sup>2</sup> at basement level                            |
| Café / Restaurant | 52m <sup>2</sup> at ground floor                               |

**Table 1** | Schedule of Accommodation

Please also refer to the accompanying Application Form and Planning Report for a full detailed description of the development.

### 2.1 Roof Level

Although it has not been possible to inspect the whole roof space to determine the age and condition of the structure, a small area of the roof is able to be viewed through the ceiling hatch in the meeting room at third floor. The roof timbers visible do not appear to have any great age and will be inspected and tested for rot and infestation once full access is possible.

### 2.2 Third & Second Floor

The existing internal partitions will be removed where these cannot be accommodated by the proposed layouts. It will be necessary to ensure these are non load-bearing partitions before they can be safely removed, further opening up will determine this at the next stage of the project as soon as access is possible. The direction of span of the existing timber floor joists will need to be confirmed and the sizes will be checked to ensure they are suitable to support the new design loads, both dead loads and live loads.

Where floor joist are to be retained but are not adequate for the new design loads these will either be doubled up or strengthened to achieve the required performance. If the existing floor boards are found to be of interest from a heritage perspective these will be examined to see if they are free of rot and could be reused. If they are damaged or do not have heritage value the floor will be boarded with a new floor boarding screwed down to the existing or new floor joists.

Where new openings are required over new doorways these will be selected based on the span and applied loads, the strength of the original brickwork and mortar will be assessed and the beams or lintels will be provided with new padstones at the supports and a minimum of 100mm bearing into the walls.

At Second floor there is also a later added extension that is to be demolished to return the rear of the building to its original profile.

## **2.3 First Floor**

The existing staircase from ground floor to first floor is to be replaced and the staircase that currently begins at first floor and rises up to second and third floors is to be extended downwards to basement level. A new stair shaft opening through the floor at first floor is therefore required.

Given the extent of the work the entire floor is likely to be replaced unless the floor joists are found to be original to the building and of heritage interest. In this situation efforts will be to retain existing timbers where possible but given the intrusive work involved some may have to be replaced.

## **2.4 Ground Floor**

The existing Ground floor is believed to comprise of timber floor joists and floor boards although this has yet to be confirmed. It is also possible that the floor could be a concrete structure which may have been constructed in the 1913 works, when the ground floor space was opened up by the addition of the plate girder spanning across the width of the building.

The existing staircase from ground floor to first floor is to be removed and the staircase that currently begins at first floor and rises up to second and third floors is to be extended downwards to basement level. A new stair shaft opening through the floor at Ground floor is therefore required.

A platform lift is also proposed to enable access to the basement, this will also require an aperture to be formed in the ground floor structure.

The new ground floor also includes the creation of the pedestrian thoroughfare. To the rear of the building a new external yard/ refuse and bicycle store is also required. These areas will need to be provided with a waterproofing membrane, insulation and external works finishes which are to be specified by the architect. The structure may need to be stepped down at these external areas in comparison to the internal areas to allow for the thickness of the finishes and to enable the passageway and external yard areas to be flush with the surrounding levels of the public footpath along O'Connell Street Upper and Henry Place to the rear.

## **2.5 Basement Level**

The existing basement is to be retained. We do not envisage extensive work to the building foundations with the exception of a new lift pit for the passenger hoist proposed between ground and basement floors.

The existing basement will need to provide a habitable environment suitable for the residential use and the slab and perimeter walls will need to be investigated further in the following stages of the project.

The basement slab is thought to be original to the building or it may have been replaced in the 1960's when the ground floor alterations were carried out. In either case the slab may not be suitable for the long future term use and may need to be replaced.

Also there is unlikely to be any thermal insulation, damp proof membrane or Radon Gas membrane in the existing condition. Adding this above the existing basement slab would reduce the basement space headroom but needs to be investigated further, replacing the slab would offer the opportunity to maintain headroom.

### 3. Site Setup

Site access will be provided to the rear of the site via Henry Place with a secondary access provided onto O'Connell Street Upper. The site welfare, office and meeting rooms will be provided on Levels 3 & 4 within the existing building. The existing hoarding to 61 O'Connell Street Upper shall be maintained to the front and rear.

The primary vehicle drop-off and site entrance will be located off Henry Place to the rear. A temporary loading bay will be controlled with drop-offs made on a just-in-time delivery.

A preliminary site setup layout is shown in Figure 2.

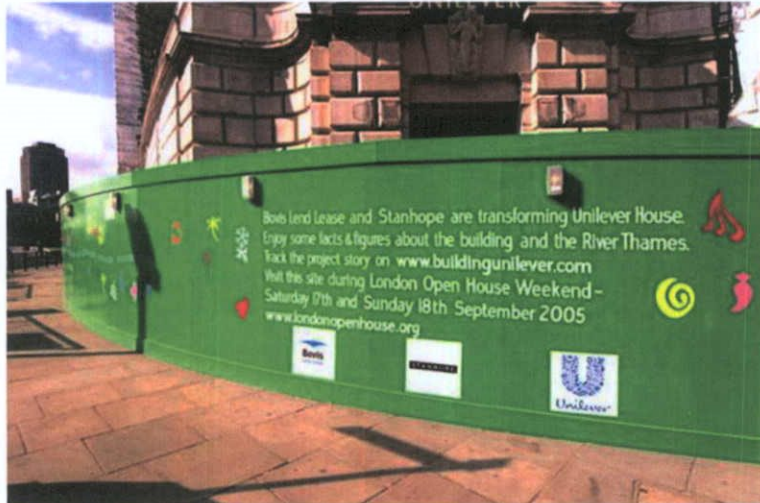

**Figure 2 | Proposed Site Setup**

The Contractor will keep all public roads and footpaths entirely free of excavated material, debris, rubbish, construction materials and equipment.

#### 3.1.1 Perimeter Hoarding

The hoarding line will be maintained at all times during demolition and construction. In the event of any of the hoarding having to move outwards to facilitate construction activities, this will be done with the agreement of Dublin City Council including obtaining new hoarding licenses as required. If this encroaches on minimum footpath widths, the Contractor will erect diversions to opposite footpaths to the agreement of Dublin City Council.



**Figure 3 | Typical Perimeter Hoarding**

Where there are ESB/telecommunication kiosks, light poles and traffic signage on the footpaths these will be maintained by the Contractor where practical.

### 3.1.2 Site Compound

The site compound may consist of:

- Offices
- Meeting Rooms
- Toilet / Shower Rooms
- Drying Rooms
- Canteens
- Storage Containers

### 3.1.3 Access & Egress

Safety and ease of access to the site are to be provided for by the Contractor when planning the works. Separation of vehicular and heavy plant traffic from pedestrians and operatives will be implemented as far as is practical when considering the layout of the site infrastructure and access points.

Where a site access crossing is required on a pavement this will require a dedicated pedestrian management setup to ensure there are no incidents of crossovers between pedestrians and site vehicles. This may require a turtle gate barrier in addition to with semi-permanent barriers along the kerb edge, flagmen to control barriers and flagmen to watch truck movement and pedestrians.

### 3.1.4 Logistics

The site will likely require mobile cranes and hoists to service the construction activities. This will include all stages of the works including the repair works to the existing building envelope.

The construction traffic and pedestrian routes are outlined in the Outline Construction Traffic Management Plan submitted as part of this planning application. In general, trucks will be off loaded from the designated laydown areas on Henry Place. Deliveries will typically be on a just-in-time basis and this system will be strictly controlled by Contractor who will organise the deliveries. The Contractor will advise their suppliers on the delivery routes, ensuring the drivers are made aware of the site location and confinements around the site.