



---

# Meath-Tyrone 400kV Interconnection Development

## Tower Outline Evaluation and Selection Report

---

PE687-R141-015-001-001

---

ESBI Engineering & Facility Management Ltd  
Stephen Court, 18/21 St Stephen's Green, Dublin 2, Ireland  
Telephone+353-1-703 8000 Fax+353-1-661 6600  
[www.esbi.ie](http://www.esbi.ie)

30/11/09

---



<b>File Reference:</b>	Meridian - PE687-R141	
<b>Client / Recipient:</b>	EirGrid/NIE	
<b>Project Title:</b>	Meath-Tyrone 400kV Interconnection Development	
<b>Report Title:</b>	Tower Outline Evaluation and Selection	
<b>Report No.:</b>	PE687-R141-015-001-001	
<b>Rev. No.:</b>	1	
<b>Volume 1 of 1</b>		
<b>Prepared by:</b>	Jarlath Doyle	
<b>Title</b>		
<b>APPROVED:</b>	J.Doyle	<b>DATE:</b> 30/11/09
<b>TITLE:</b>		

**Latest Revision Summary:**

Issue of final report. No comments received from client on initial draft.  
 Minor edits to Figure 7-5, as per client comments.

**COPYRIGHT © ESB INTERNATIONAL LIMITED**

ALL RIGHTS RESERVED, NO PART OF THIS WORK MAY BE MODIFIED OR REPRODUCED OR COPIES IN ANY FORM OR BY ANY MEANS - GRAPHIC, ELECTRONIC OR MECHANICAL, INCLUDING PHOTOCOPYING, RECORDING, TAPING OR INFORMATION AND RETRIEVAL SYSTEM, OR USED FOR ANY PURPOSE OTHER THAN ITS DESIGNATED PURPOSE, WITHOUT THE WRITTEN PERMISSION OF ESB INTERNATIONAL LIMITED.

## Table of Contents

1	Introduction	2
2	Tower Outline Evaluation: by ESBI	3
3	New Tower Loadings: by ESBI	3
4	Visual Impact Study: by AECOM	4
4.1	Tower Types	4
4.2	Visual Assessment of New Tower Outline	5
4.3	Insulator Material Type: Glass or Composite	5
5	Hot Rolled versus Cold Formed Steel	6
5.1	Manufacturing Processes	6
5.1.1	Hot Rolled Steel	6
5.1.2	Cold Formed Steel	6
5.2	Hot Rolled Vs Cold Formed Lattice Towers	7
5.2.1	Advantages/Disadvantages	7
6	Foundations	8
6.1	Foundation Design Analysis	8
6.2	Analysis of Results	9
7	Electrical Parameters	10
7.1	Study Outline	10
7.2	Electric and Magnetic fields	10
7.3	Radio Interference and Audible Noise	11
7.4	Surge Impedance Loading	12
7.4.1	Results	13
8	Insulation Coordination: by PB Power	15
8.1	Scope of study	15
8.2	Initial results	15
9	Conclusions	16
10	Appendix 1	17

## List of Figures

Figure 4-1 Proposed 400kV Tower Outline Drawings (not to scale).....	4
Figure 4-2 Comparative Visual Appraisal.....	5
Figure 4-3 Models of Insulators (a) Glass (b) Composite .....	5
Figure 5-1 Hot Rolled C- IVI-1 Tower Head b) Cold Formed C- IVI-1 Tower Head.....	7
Figure 6-1 Type BC and C and Foundation Outline.....	8
Figure 6-2 Foundation Loads for different Tower Configurations.....	9
Figure 6-3 Comparison Table of Foundation dimensions for different Tower Configurations .....	9
Figure 7-1 IVI Tower Calculated Electric and Magnetic Field Graphs. ....	11
Figure 7-2 Radio Interference Voltage and Audio Noise of each Tower Configuration.....	12
Figure 7-3 Surge Impedance Loadings of each Tower Configuration. ....	13
Figure 7-4 Electrical Calculation Comparison .....	13
Figure 7-5 Electrical Calculation Comparisons at 50m orthogonal from centre of overhead line .....	14

# 1 Introduction

EirGrid and NIE have commissioned ESBI, SAE Power Lines, and AECOM (formally know as Faber Maunsell) to perform various studies on a number of 400kV tower designs to determine which design is technically and aesthetically suitable to employ on the new Meath-Tyrone 400kV Interconnection Development. The studies performed are as follows:

- Tower Outline Evaluation, by ESBI
- Visual Assessment of New Tower Outline Impact Study, by AECOM
- Foundation Design, by ESBI
- Electrical Calculations, by SAE PL & ESBI, including:
  - Electrical and Magnetic Fields
  - Surge Impedance
  - Audible Noise and Radio Interference
- Insulation Coordination Study, by PB Power

The following four towers were evaluated based on the above criteria:

1. Standard 401<sup>\*</sup>
2. IVI Configuration<sup>†</sup>
3. VVV Configuration<sup>†</sup>
4. Inverted Delta Configuration<sup>†</sup>

This report gives a summary of each study above and based on the results of each study ESBI have concluded in a proposal for the 400kV tower design to be employed on the Meath-Tyrone 400kV Interconnection Development.

---

<sup>\*</sup> Referred to by Faber Maunsell as Standard NL 401

<sup>†</sup> IVI, VVV, and Inverted Delta denotes the insulator configuration within the tower

## 2 Tower Outline Evaluation: by ESBI

To initialise the process of designing a new 400kV tower a comparative evaluation on a number of tower types was performed. The designs included a number of lattice steel structures, wooden structures, monopole structures and other alternative designs. For the full report see PE687-R141-005-001-000.

Each design type was assessed based on criteria agreed by both utilities. Following evaluation of all the proposed tower types' three lattice designs were chosen. They are:

- Existing ESB 400kV Tower Series
- Raised Centre Phase Tower Design
- Closed Window

## 3 New Tower Loadings: by ESBI

For the design of the new 400kV tower the tower loadings required to be derived. It was agreed in report Proposed Criteria for 400kV Interconnector Line, PE687-R141-007-001-008, that the loading condition requirements of both utilities would be adhered to.

To apply the loading conditions it was agreed that IEC 60826 would be broadly used, taking into account previous ESB 400kV line design, with consideration given to NGTS 2.27 and EN 50341 where practicable. IEC 60826 is an international standard since 2003. It specifies the loading and strength requirements of overhead lines greater than 45kV. There are three requirements to be adhere to in this standard, they are reliability (wind loads, wind and ice loads, with a return period T), security (cascade loads), and safety (construction and maintenance loads). Tower loadings were derived for intermediate, 0 - 30°, 0 - 60°, and 60 - 90° towers.

For the new 400kV tower the following were applied:

- Reliability level 2 (return period T = 150yrs) would be applied to the interconnector.
- The reference wind speed of 36m/s was estimated with the use of a Gumbel distribution and statistical data from Shannon Airport synoptic station.
- Equivalent, weight, and wind span of the original ESB 400kV tower were adhered to.
- Tower loadings corresponding to the phase conductor of 600mm<sup>2</sup> ACSR Curlew, and earthwire of OPGW 160 mm<sup>2</sup> ACSR Keziah equivalent (AA/ACS 177/51) were derived.
- The high probability wind with low probability ice load was derived with EN 50341 – 3 – 11 NNA for Ireland as this was most onerous.

## 4 Visual Impact Study: by AECOM

EirGrid and NIE commissioned an independent review of each of the 400kV designs for reduction of visual impact of a 400kV overhead line on the landscape. AECOM landscape architects were employed to perform a comparative evaluation of the likely visual effects of each of the following four 400kV Single Circuit tower designs:

- Standard NL 401 (with new loads) \*
- C-IVI-1
- C-VVV-1
- Inverted Delta

### 4.1 Tower Types

As stated above four different 400kV tower designs were chosen for analysis. Each of the last three can be produced with hot rolled or cold formed steel. The differences between rolled and cold formed steel is given in detail in the section 5 of this report.

Shown below in figure 4-1 is an outline of each of the proposed designs. A description of the design and configuration of each of the towers follows.

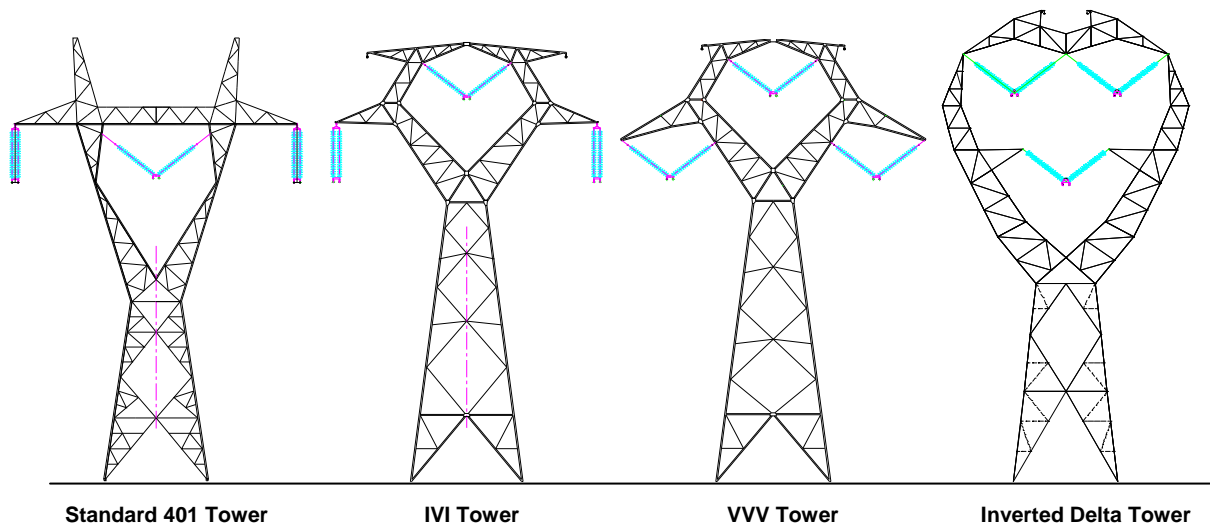

**Figure 4-1 Proposed 400kV Tower Outline Drawings (not to scale)**

\* 401: Existing ESB 400kV design

## 4.2 Visual Assessment of New Tower Outline

AECOM produced a visual assessment report comparing the four towers based on both a quantitative and qualitative approach. A full description of the methodology used for each approach is given within the report. From the quantitative and qualitative appraisal of each tower the most preferred tower resulted. Figure 4-2 below gives the order of preference of tower design based on the results.

Tower Design	Quantitative Appraisal Score	Effective Comparative Visual Impact	Order of Preference
NL-401	36	High	3 <sup>rd</sup>
C-IVI-1	32	Medium	1 <sup>st</sup>
C-VVV-1	33	High	2 <sup>nd</sup>
Inverted Delta	37	High	4 <sup>th</sup>

**Figure 4-2 Comparative Visual Appraisal**

This preference is based only on a visual assessment of the towers, and while this is an important aspect of the choice of tower it must be evaluated with other aspects of the line that have an influence on the tower design selection. These are discussed in the following sections.

## 4.3 Insulator Material Type: Glass or Composite

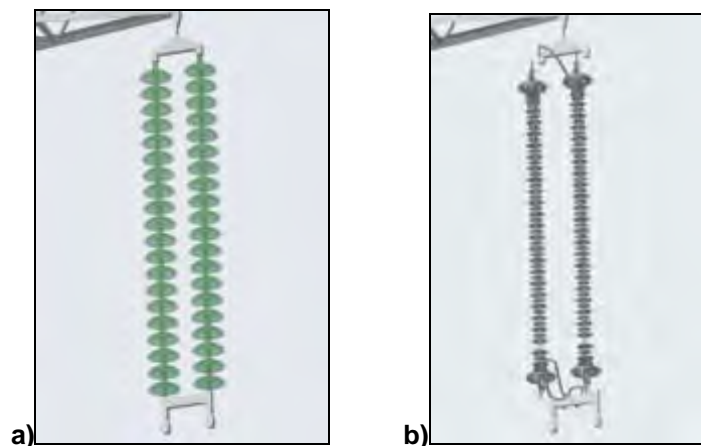

**Figure 4-3 Models of Insulators (a) Glass (b) Composite**

The photomontages (see figure 4.3) also illustrate the use of two different types of insulator sets; glass and composite. While the insulator material was not considered as part of the visual appraisal of each tower their visual impact on the landscape was evaluated independently by AECOM.

The study reveals that glass insulators would be more visible and prominent due to its tendency to reflect light more making it the overall tower more conspicuous upon the landscape. Being dull grey composite insulators do not draw attention to the insulator arrangement in the same way that the glass insulators do. The composite insulator is therefore better suited to reduce the visual impact of the tower.

The composite insulator set would be more than 3 times lighter than its glass counterpart making handling for construction much easier.

Also, with increased popularity of composite insulators their cost has reduced to be comparative to glass insulator costs.



---

## 5 Hot Rolled versus Cold Formed Steel

Theoretically, the only difference between hot rolled and cold rolled steels is that hot rolled steel is rolled to its final dimensions while hot enough to scale, whereas cold formed steel is formed to its final dimensions at ambient temperature.

### 5.1 Manufacturing Processes

#### 5.1.1 Hot Rolled Steel

The process of hot rolling, used mainly to produce sheet metal or simple cross sections from billets, concerns the method of when metal is passed or deformed between a set of rollers at a temperature generally above the metals re-crystallization temperature, as opposed to cold rolling, which takes place below this temperature. This permits large deformations of the metal to be achieved with a low number of rolling cycles. When the metal cools the crystals of the metal reform. Because the metal is worked before crystal structures have formed, this process does not itself affect its micro-structural properties. Hot rolling is primarily concerned with manipulating material shape and geometry rather than changing the mechanical properties of the material.

Hot rolled steel is used as a primary manufacturing process where the steel is produced in ingots or sheet metal of varying sizes to be used to manufacture the final product which itself can either be hot rolled or more commonly cold formed. Products from the hot rolling process include car wheels, brakes, body structural components, suspension components, etc. Heavy construction material like I-beams, angle sections, box sections and tubing can also be hot rolled.

Hot rolling steel is one way to prepare steel for application but retaining some amount of its ductility. The heat actually prohibits the small imperfections from forming.

#### 5.1.2 Cold Formed Steel

Cold formed shapes are obtained by bending strips of steel. The shapes are produced from a piece of flat rolled steel and are bent at ambient temperature to obtain the desired shape either by use of bending presses or by roll forming. Roll forming requires a rolling machine with a series of rollers, where the steel strip undergoes successive bending until it has reached the desired shape. As metal is worked from one reducing mill to the next, the grain structure is rearranged in such a manner that the steel becomes harder and more brittle.

Cold formed steel has a much finer grained, smoother and less porous surface. This is so because cold forming tends to 'fold in' and close up the pores. The less porous the surface, the less surface area is presented to chemical attack by acids, alkalis, and phosphate compounds. Hot rolled steel is more porous and therefore more reactive to chemicals.

Cold-formed members can be produced in a wide variety of sectional profiles, the most commonly used of which are the channels and the Z sections. While plain sections are finding applications as secondary members, the sections are usually enhanced with flange end stiffeners (e.g. the lipped channels) and/or web stiffeners in primary structural applications. With stiffeners, the members benefit from a larger cross-sectional effective area and are therefore expected to become better able to resist local and overall buckling. Cold-formed steel products are used in buildings, automobiles, bridges, etc.

## 5.2 Hot Rolled Vs Cold Formed Lattice Towers

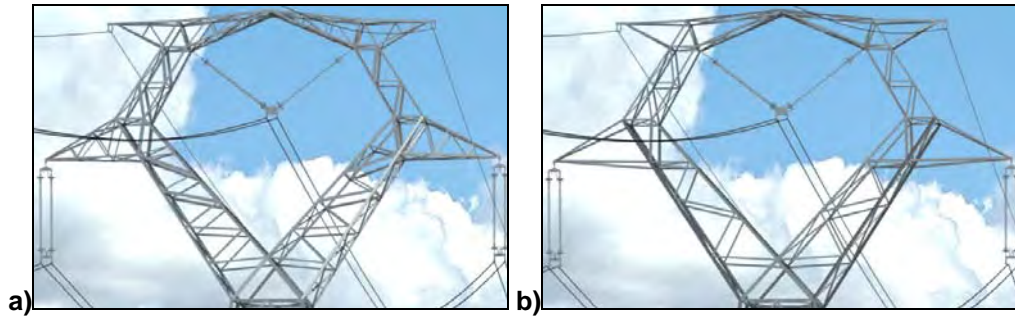

**Figure 5-1 Hot Rolled C-IVI-1 Tower Head b) Cold Formed C-IVI-1 Tower Head**

The principal difference, which is an important factor in the towers visual appearance, is that cold formed members are notably fewer which results in a more open, simple structure. Cold formed members are bulkier and provide a slightly denser composite to the hot rolled structure.

Costs show approximately €2200/ton and €3500/ton for hot rolled steel and cold formed steel respectively. Therefore a cold formed tower would cost up to 60% greater than a hot rolled steel tower.

### 5.2.1 Advantages/Disadvantages

#### 5.2.1.1 Hot Rolled Steel

- A greater number of manufacturers produce hot rolled tower designs which would give greater scope for tender.
- The cost advantage as given above.
- Hot rolled towers have the disadvantage of taking longer to construct as more members must be assembled.

#### 5.2.1.2 Cold Formed Steel

- There are from 20% to 50% less members in a cold formed tower to that of hot rolled towers. With fewer members in the cold rolled tower the assembly time is reduced.
- An advantage of the cold formed tower is that it can be less visually obstructive over the landscape.
- From previous tenders only one European manufacturer of cold formed towers exists, and transportation costs from manufacturers elsewhere increase the cost considerably.

## 6 Foundations

The foundation of the tower is the means by which the loads are transmitted from the structure into the surrounding soil. The foundation is designed to withstand the maximum uplift, compression, transverse shear, and longitudinal shear loads imposed by the tower. The foundation should be stable enough to prevent any movement of the mast under the maximum loading conditions.

For the purpose of evaluating the proposed 400kV tower designs a foundation analysis was also performed. The analysis compares the difference in dimensions and loadings of each of the towers. The towers analysed are listed below:

- Existing ESB design
- IVI Tower
- VVV Tower
- Inverted Delta Tower

### 6.1 Foundation Design Analysis

For the purpose of comparison the type C foundation (Tower type 407, foundation design TD6246) has been examined for the 4 different tower configurations (see WI-EP5A-005-003-000). The type C foundation is installed in slightly unstable ground and is shown in figure 6-1.

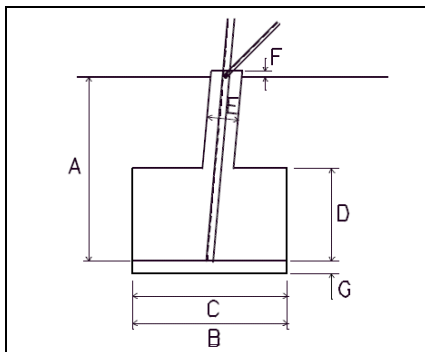

**Figure 6-1 Type BC and C and Foundation Outline**

To carry out the foundation design comparison certain criteria were assumed, they were:

- Maximum Uplift Load,  $U_m$
- Maximum Compressive Load,  $C_m$
- Maximum Transverse Shear Load,  $T_s$
- Maximum Longitudinal Shear Load,  $L_s$

The design criteria assumed for the generic standard type C of foundation are:

- Soil Bearing Capacity,  $BP_{soil} = 10,000 \text{ kg/m}^2$
- Soil Shear Angle,  $\phi = 15^\circ$
- Density of Soil,  $\rho_{soil}$ : assumed to be  $1,600 \text{ kg/m}^3$
- Density of Concrete,  $\rho_{conc}$ : Assumed to be  $2,300 \text{ kg/m}^3$
- Concrete Cube Strength,  $f_{cu} = 25 \text{ N/mm}^2$
- Design Strength of Concrete in Compression,  $F_{oc} = 0.45f_{cu} = 11.25 \text{ N/mm}^2$
- Design Strength of Concrete in Tension,  $fat = 0.045f_{cu} = 1.125 \text{ N/mm}^2$
- Maximum Shear Stress =  $0.045f_{cu} = 1.125 \text{ N/mm}^2$
- Maximum Punching Shear Stress =  $0.09f_{cu} = 2.25 \text{ N/mm}^2$

- Maximum Bond Stress =  $0.06f_{cu} = 1.5 \text{ N/mm}^2$

In Figure 6-2 the calculated foundation loads are given for each of the proposed towers with hot rolled steel, as they resulted in the worse loadings.

	<b>401 (SAE)</b>	<b>C-IVI-1</b>	<b>C-VVV-1</b>	<b>Inv. Delta</b>
Max Compression Leg	606kN	641 kN	629 kN	716 kN
Max Uplift / Leg	503 kN	504 kN	495 kN	547 kN
Transverse Shear / Leg	33 kN	42.5 kN	35.5 kN	30 kN
Longitudinal Shear / Leg	25 kN	42.5 kN	35 kN	30 kN

**Figure 6-2 Foundation Loads for different Tower Configurations**

In Figure 6-3 the foundation dimensions for the 4 towers are compared, derived from ESBI calculations.

<b>Dimension(mm)</b>		<b>A</b>	<b>B</b>	<b>C</b>	<b>D</b>	<b>E</b>	<b>F</b>	<b>G</b>	<b>H</b>	<b>K</b>
<b>Tower Type</b>	<b>New 401</b>	2600	2600	2600	1200	600	100	200	1000min	1200min
	<b>I V I</b>	2600	2600	2600	1200	600	100	200	1000min	1200min
	<b>V V V</b>	2600	2600	2600	1200	600	100	200	1000min	1200min
	<b>Inv. Delta</b>	2600	2750	2750	1200	600	100	200	1000min	1200min

**Figure 6-3 Comparison Table of Foundation dimensions for different Tower Configurations**

## 6.2 Analysis of Results

From reviewing the information given in Figure 6-2 it is clear that the greatest loadings applied to a foundation regarding uplift, transverse shear, and longitudinal shear would be from the IVI tower type, while the Max Compression load would be applied from the Inverted Delta tower. In terms of foundation dimensioning the Compression load has the greatest influence on the required bearing area and that would result in a larger foundation.

The results in figure 6-3 show that the applied loadings from the tower types 401, IVI, and VVV, would result in a foundation depth and width of 2.6m X 2.6m respectively while the loading applied from the Inverted Delta tower would result in a larger foundation dimensions, 2.6mx2.75m. Overall there is no significant difference in the foundation dimensions of any of the candidate designs.

---

## 7 Electrical Parameters

### 7.1 Study Outline

An independent study was commissioned by ESBI and performed by SAE Power Lines on the potential electrical effects created by each of the tower configurations being compared. The electrical study produced results based on the calculations for the following:

- Electric and Magnetic Fields
- Radio Interference and Audible Noise
- Surge Impedance

The full report can be seen in P06E5010-HSC 008.

The tower material (hot rolled and cold formed) has no influence on results. The calculations are based on the tower configuration (see appendix 1 for insulator configuration dimensions) of the four tower types as given below.

- Standard 401 tower configuration
- IVI tower configuration
- VVV tower configuration
- Inverted Delta tower configuration

A fuller discussion and analysis of the issue associated with EMF and audible noise will be presented in the EIS which will be submitted as part of the planning application.

### 7.2 Electric and Magnetic fields

Electric and magnetic fields both occur naturally. The Earth's magnetic field, which is due mainly to currents circulating in the outer layer of the Earth's core, varies between about  $30\mu\text{T}$  (micro Tesla,  $1000\mu\text{T} = 1\text{ mT}$ , milliTesla) at the equator and about  $60\mu\text{T}$  at the poles. This field may be distorted locally by ferrous minerals or by steelwork such as in buildings.

At the Earth's surface there is also a natural electric field, created by electric charges high up in the ionosphere, and varying between 100 and 150V/m in fine weather. Below a storm cloud containing large quantities of electric charge, the field may reach intensities up to 20kV/m over flat surfaces, while above hillocks or other irregularities or near the tops of objects such as trees, the field strength can be considerably higher.

Power systems generally use alternating voltages and currents and hence the fields they produce are also alternating. Power lines on the island of Ireland operate at 50 cycles per second (hertz or Hz); so voltage, current and fields each alternate at this frequency.

The International Commission on Non-Ionising Radiation Protection (ICNIRP), who are the World Health Organisation advisors on non-ionising radiation matters, issued guidelines in 1998 for exposure limits from 50Hz electric and magnetic fields. In determining their guidelines ICNIRP reviewed the body of scientific literature which existed on EMF and set the basic restriction for the induced current density in the body as  $10\text{mA/m}^2$  and  $2\text{mA/m}^2$ , respectively for occupational and general public exposure. As induced current density in the human body is not measurable, ICNIRP produced reference levels for both electric and magnetic field exposure.

The electric and magnetic fields were calculated for twin 600 ACSR CURLEW phase conductor with the phase spacing relative to each respective tower configuration (see appendix 1). The calculations were performed on a corridor of 100m orthogonal to the centre line of a 400kV line span, at clearance of 9m (as agreed in proposed criteria document PG 567-R141-007-001-008).

The electric field was evaluated considering a maximum operating voltage of 420kV. The magnetic field was evaluated considering a normal operating current of 1443A and a maximum operating phase current of 2166A. An example of the electrical and magnetic field results can be seen in figure 7-1 below.

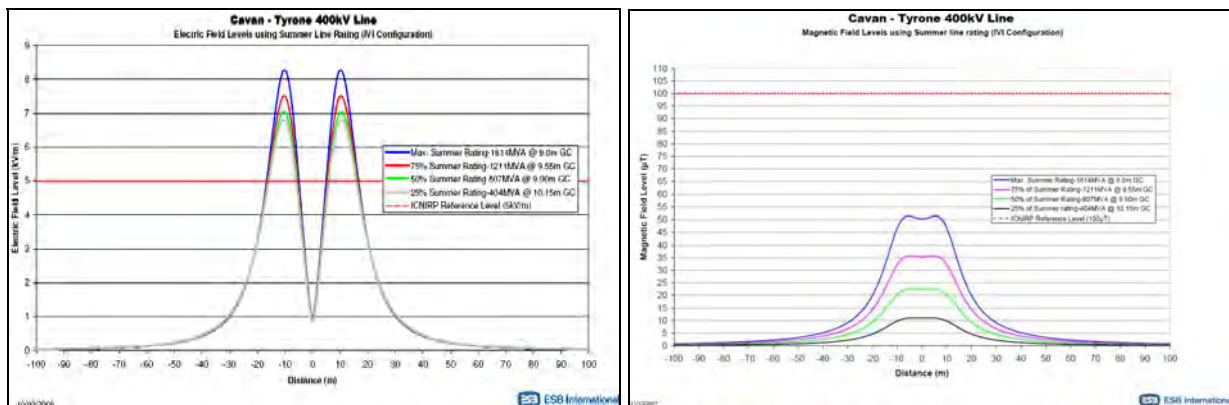

Figure 7-1 IVI Tower Calculated Electric and Magnetic Field Graphs.

### 7.3 Radio Interference and Audible Noise

As transmission system voltages increase, audible noise produced by corona on transmission line conductors should be analysed and examined to ensure tolerance levels cannot be exceeded. Audible noise from transmission lines occurs primarily in bad weather. Water drops impinging or collecting on the conductor produce a large number of corona discharges, each of them creating a burst of noise. In dry conditions, the conductors usually operate below the corona inception level, and very few corona sources are present.

The lowest threshold of hearing is 0 dB(A). The scale is logarithmic, so an increase of 10dB(A) is a ten-fold increase in the intensity of a sound. However, it is perceived as a doubling of the loudness of a sound.

Examples of typical sound levels are:

- Whispering: **30 dB(A)**
- Rural night-time noise: **20-40 dB(A)**
- Conversation: **60 dB(A)**
- Truck at 30 mph 300 feet (91.44m) away: **65 dB(A)**
- Vacuum cleaner: **70 dB(A)**

The distance from the sound source affects the level of sound that is heard. Due to the physical nature of sound, doubling the distance means the sound is only one fourth as loud as it was at the original distance.

The two most important Radio Interference (RI) and Audible Noise (AN) sources are corona and gaps. Weather conditions and the effect of line and conductor geometry mainly influence on RI and AN

performance. Parameters that have the most significant effect on RI and AN levels are the number of conductors in a phase bundle and the diameter of the conductors. An increase in either will result in a reduction of RI and AN. The spacing of the conductors within a bundle has more complex effect on noise levels. However, except for very small spacing, the variation from the optimum is slight. Increasing the phase spacing of single circuit lines lowers the conductor surface gradient, and thus, the RI and AN produced.

For the SAE Power Lines study the radio interference and audible noise results were produced from a computer program based on CEI 211-4 (Italian Electrical Committee) and validated on TERN 230 and 420 line measurements and is substantially based on the Bonneville Power Administration (BPA) method. The parameters for the RI and AN calculations were based on those previously explained in 7.2, Electric and Magnetic Fields. The zero sequence parameters have been calculated with a soil resistivity of 200  $\Omega/m$ , while the operating voltage applied to the calculations was 400kV. The results of the calculations can be seen from the graph in figure 7-2.

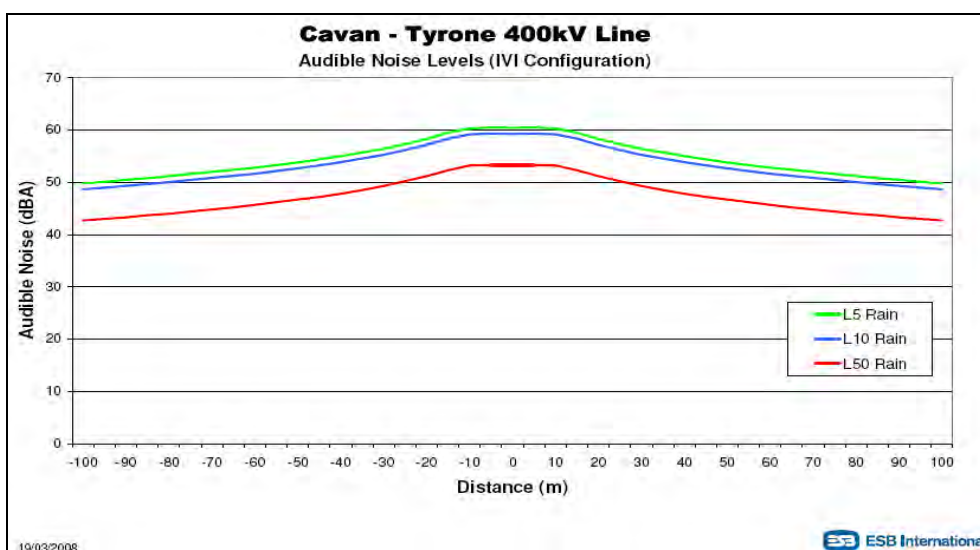

Figure 7-2 Radio Interference Voltage and Audio Noise of each Tower Configuration.

## 7.4 Surge Impedance Loading

The power transfer capability of a transmission line is usually expressed in terms of Surge Impedance Loading (SIL). It is a measure of the positive inductive and capacitive reactance of a transmission line. It is a parameter determined by the line design since it only depends on the line impedances. The positive sequence surge impedance of a transmission line is sometimes considered a measure of the load capacity of a line under practical conditions. It is a useful basis of comparison of different line designs and different operating voltages and serves as a check on the practicality of a given line loading.

Transmission lines produce reactive power (Mvar) due to their natural capacitance. The amount of Mvar produced is dependent on the transmission line's capacitive reactance ( $X_C$ ) and the voltage (kV) at which the line is energized. Transmission lines also utilize reactive power to support their magnetic fields. The magnetic field strength is dependent on the magnitude of the current flow in the line and the line's natural inductive reactance ( $X_L$ ). It follows then that the amount of Mvar used by a transmission line is a function of the current flow and inductive reactance. A transmission line's Surge Impedance Loading is simply the MW loading (at a unit power factor) at which the line's Mvar usage is equal to the line's Mvar production.

The Surge Impedance of any transmission line, whether power frequency or radio frequency is:

$$Z_0 = \sqrt{X_L \cdot X_C}$$

Where  $X_L$  and  $X_C$  are the inductive and capacitive reactance per unit length, respectively. The surge impedance is measured in ohms.

For a three phase line, the Surge Impedance Loading is:

$$SIL(3\Phi) = kV_{LL}^2 / Z_0$$

For the SAE Power Lines study the surge impedance loading results were produced by a computer program developed for electric system simulation (Electromagnetic Transients Program (EMTP)/Alternative Transient Program (ATP)), validated on various high voltage examples.

The parameters of the SIL calculations were based on those previously explained in 7.2, Electric and Magnetic Fields. The zero sequence parameters have been calculated with a soil resistivity of 200Ω/m, while the operating voltage applied to the calculations was 400kV, and also 420kV.

The results of the calculations can be seen in the graph in figure 7-3 below.

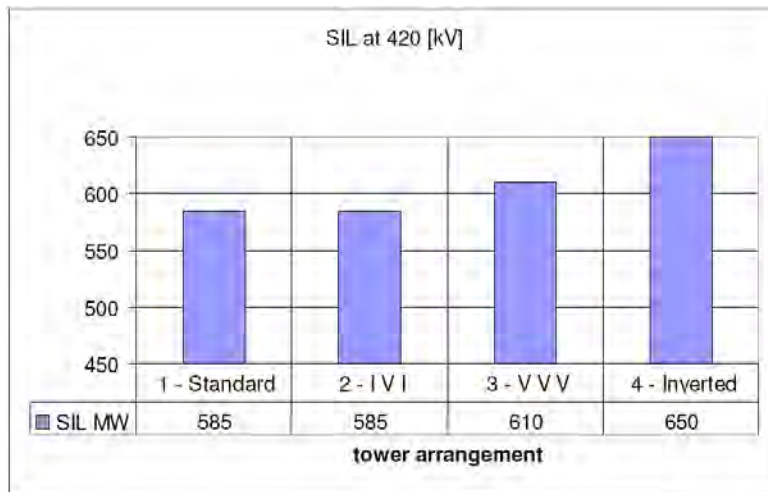

Figure 7-3 Surge Impedance Loadings of each Tower Configuration.

#### 7.4.1 Results

The electrical study results of each of the tower configurations are compared in figures 7-4 and 7-5. For each of the electric and magnetic field results given the maximum values calculated are presented. The Radio Interference and Audible Noise results are given at 20m and at the corridor extremes of 50m.

	Maximum Electric Field @ 420kV	Maximum Magnetic Field @ 1443A	Maximum Magnetic Field @ 2166A	Radio Interference @ 1μV, 20m	Audible Noise, 20m	Surge Impedance Loading @ 420kV
<b>401</b>	8.25kV/m	34.5μT	56.0μT	55.5dB	49.0dBA	585MW
<b>C-IVI-1</b>	8.30kV/m	34.0μT	48.0μT	55.8dB	49.2dBA	585MW
<b>C-VVV-1</b>	7.85kV/m	32.0μT	47.0μT	56.9dB	50.1dBA	610MW
<b>INVERTED DELTA</b>	6.55kV/m	18.5μT	28.0μT	58.2dB	51.6dBA	650MW

Figure 7-4 Electrical Calculation Comparison



	<b>Electric Field @ 420kV</b>	<b>Magnetic Field @ 1443A</b>	<b>Radio Interference @ 1μV</b>	<b>Audible Noise</b>	<b>Surge Impedance Loading</b>
<b>401</b>	0.246kV/m	2.09μT	45.9dB	45.8dBA	N/A
<b>IVI</b>	0.215kV/m	2.03μT	45.6dB	45.8dBA	N/A
<b>VVV</b>	0.172kV/m	1.58μT	46.0dB	46.5dBA	N/A
<b>INVERTED DELTA</b>	0.193kV/m	1.00μT	47.7dB	48.1dBA	N/A

**Figure 7-5 Electrical Calculation Comparisons at 50m orthogonal from centre of overhead line**

The results of the electrical study show close comparisons between the IVI design and the standard 401 towers.

The VVV configuration shows favourable results with regards to the electric and magnetic fields, and SIL. However higher RIV and AN levels are produced.

The Inverted Delta design gives the best results with regards to the electric and magnetic fields, and SIL. However like the VVV design comparatively higher RIV and AN levels are produced.

From this study it can be seen that as the phase's moves from horizontal to a more vertical configuration a compromise between the parameters studied can be seen.

## 8 Insulation Coordination: by PB Power

EirGrid and NIE have commissioned PB Power to perform an independent insulation co-ordination study of the new 400kV interconnector between both systems. The study considers the interconnection between both EirGrid and NIE systems performed in two stages:

Stage 1: The new 400kV overhead line will be terminated in a 400/220kV transformer in the EirGrid side and a 400/275kV transformer in the NIE side

Stage 2: A new 400kV line will be built in the EirGrid system to link the new 400kV interconnector to its existing 400kV system.

### 8.1 Scope of study

Scope of services has been produced. The outcome of the insulation co-ordination study shall be issued with recommendations following:

- An investigation and determination of the overvoltage's associated with the operation of the proposed 400kV interconnector,
- A definition of the optimum insulation levels required for the Overhead Line (OHL) and associated 400kV substations.
- A recommendation of the electrical equipment specifications with regards to insulation parameters.
- A recommendation to any operating procedures necessary for its safe and reliable operation.

In addition, the report shall specify the required insulation parameters (BIL, SIL,  $U_m$ , etc) for

- Lightning arresters
- Circuit breakers
- Transformers
- Shunt reactors (if required)
- Neutral reactors (if required)
- Additional 400kV substation equipment

### 8.2 Initial results

This study is currently still ongoing with final results yet to be received. From a review of mature draft reports it is not expected that any of the results will influence the tower design as the critical issues are satisfied through the following design parameters:

- The clearances within each tower design are well above that of the minimum clearance.
- Each tower is designed with the most onerous shielding angle of 17°.
- Each tower is designed with the larger earthwire design of Keziah AACSR.

## 9 Conclusions

This report reviewed the methods and results of each study performed for the selection of a new 400kV tower design for use on the Meath-Tyrone 400kV Interconnection Development project. A number of tower designs and configurations were evaluated with the studies varying from their visual impact on the landscape to electrical considerations.

From the results of each study as described in the body of this report the following conclusions have been made.

- Following the visual impact evaluation performed by AECOM it is considered that the IVI tower design visually imposes least on the landscape.
- It is considered that the costs of the cold formed tower compared to that of its hot rolled counterpart would be higher due to the availability of manufacturers for this style of tower.
- Visually it is considered that the composite insulator type would have lesser impact to that of glass insulators and given the comparative cost of both materials be the recommended insulator material to be used.
- Following a foundation study on each of the tower designs the small variation of the size and load of each foundation does not constitute preference of any design.
- From the electrical study performed by SAE Power Lines there is not much difference between each of the standard 401, IVI and VVV designs. The Inverted Delta design shows favourable results in the electric and magnetic fields, and SIL, but unfavourably in RI and AN calculations. The VVV results show a compromise between all electrical parameters studied.

From each of the studies it is considered that the tower design that would most satisfy all required criteria is a hot rolled steel IVI tower with composite insulators. This tower is to be adopted as the support structure design for the Meath-Tyrone 400kV Interconnection Development project.

# 10 Appendix 1

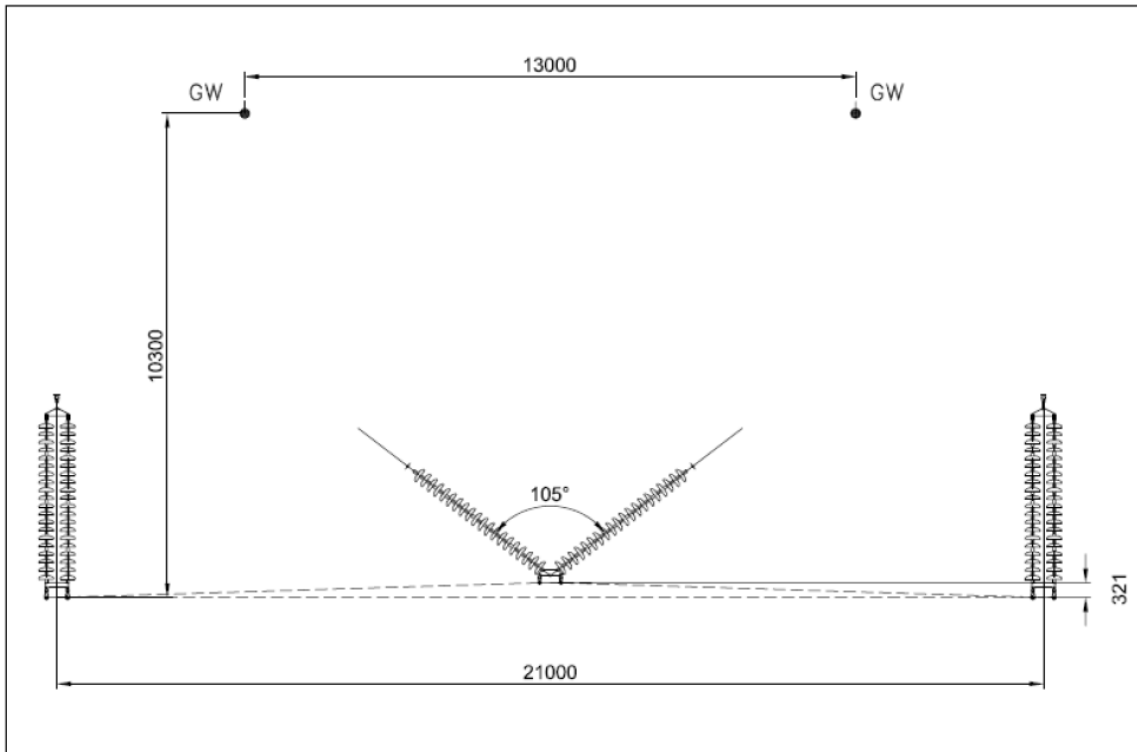

Standard NL 401 Tower Insulator Configuration

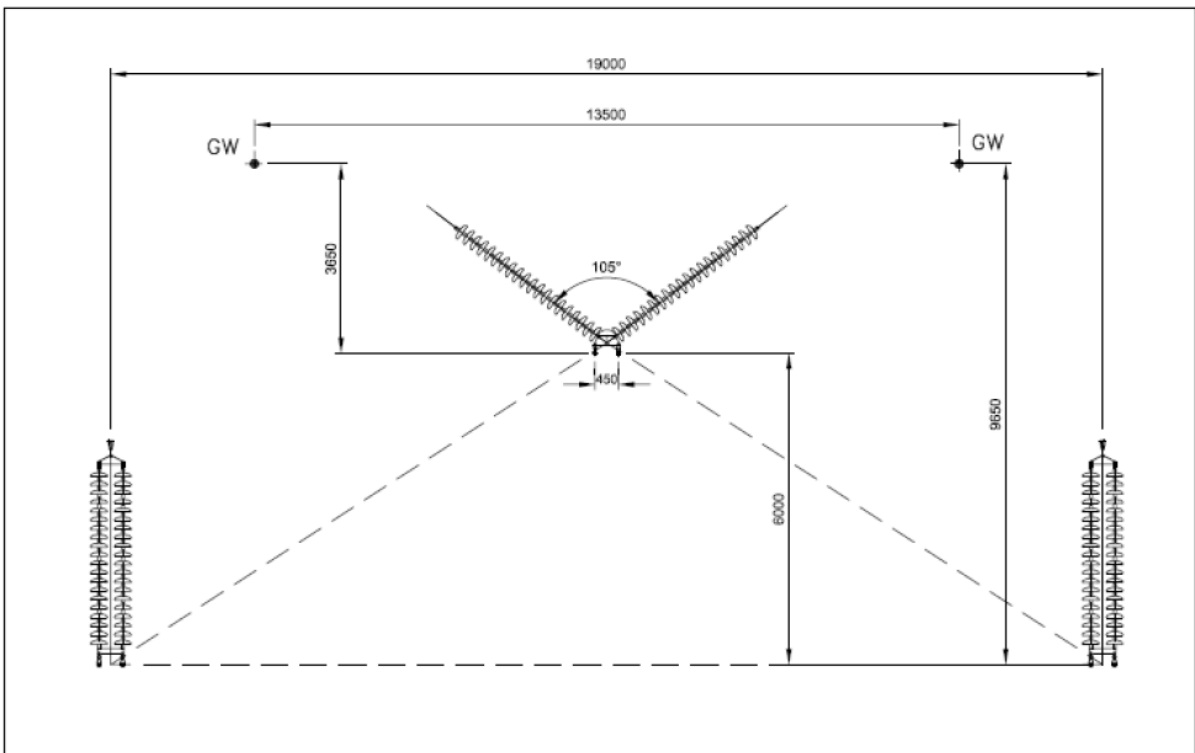

C-IVI-1 Tower Insulator Configuration

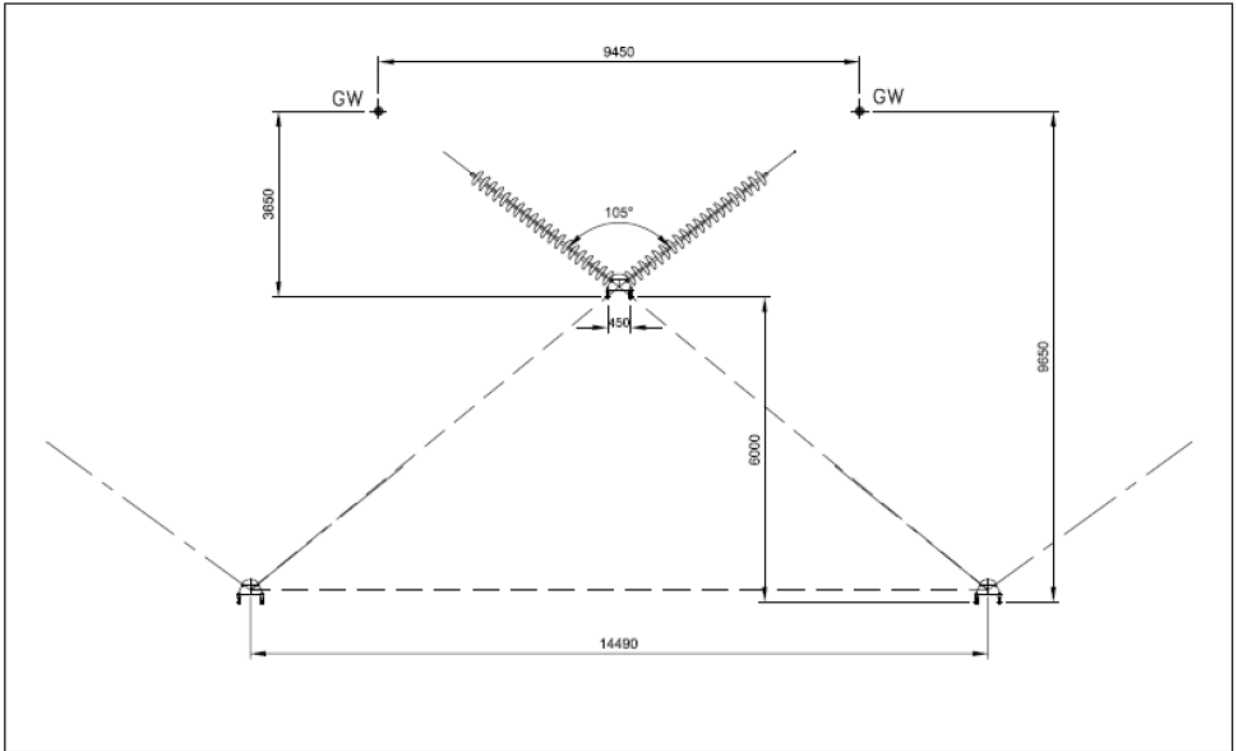

C-VVV-1 Tower Insulator Configuration

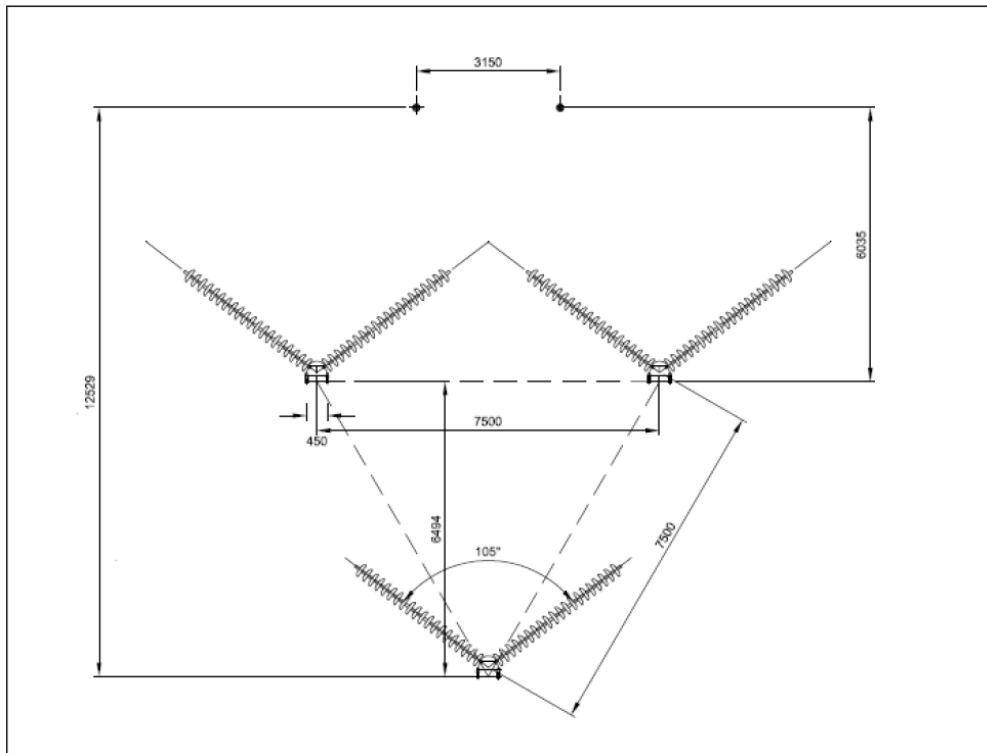

Inverted Delta Tower Insulator Configuration